

Service Manual

Finisher, Sorter, DeliveryTray Finisher-R1

Canon

Mar 22 2004

Application

This manual has been issued by Canon Inc. for qualified persons to learn technical theory, installation, maintenance, and repair of products. This manual covers all localities where the products are sold. For this reason, there may be information in this manual that does not apply to your locality.

Corrections

This manual may contain technical inaccuracies or typographical errors due to improvements or changes in products. When changes occur in applicable products or in the contents of this manual, Canon will release technical information as the need arises. In the event of major changes in the contents of this manual over a long or short period, Canon will issue a new edition of this manual.

The following paragraph does not apply to any countries where such provisions are inconsistent with local law.

Trademarks

The product names and company names used in this manual are the registered trademarks of the individual companies.

Copyright

This manual is copyrighted with all rights reserved. Under the copyright laws, this manual may not be copied, reproduced or translated into another language, in whole or in part, without the written consent of Canon Inc.

COPYRIGHT © 2001 CANON INC.









Printed in Japan

Caution

Use of this manual should be strictly supervised to avoid disclosure of confidential information.



Symbols Used

This documentation uses the following symbols to indicate special information:

Symbol	Description
	Indicates an item of a non-specific nature, possibly classified as Note, Caution, or Warning.
	Indicates an item requiring care to avoid electric shocks.
	Indicates an item requiring care to avoid combustion (fire).
	Indicates an item prohibiting disassembly to avoid electric shocks or problems.
	Indicates an item requiring disconnection of the power plug from the electric outlet.
 Memo	Indicates an item intended to provide notes assisting the understanding of the topic in question.
 REF.	Indicates an item of reference assisting the understanding of the topic in question.
	Provides a description of a service mode.
	Provides a description of the nature of an error indication.

The following rules apply throughout this Service Manual:

1. Each chapter contains sections explaining the purpose of specific functions and the relationship between electrical and mechanical systems with reference to the timing of operation.

In the diagrams,  represents the path of mechanical drive; where a signal name accompanies the symbol, the arrow  indicates the direction of the electric signal.

The expression "turn on the power" means flipping on the power switch, closing the front door, and closing the delivery unit door, which results in supplying the machine with power.

2. In the digital circuits, '1' is used to indicate that the voltage level of a given signal is "High", while '0' is used to indicate "Low". (The voltage value, however, differs from circuit to circuit.) In addition, the asterisk (*) as in "DRMD*" indicates that the DRMD signal goes on when '0'.

In practically all cases, the internal mechanisms of a microprocessor cannot be checked in the field. Therefore, the operations of the microprocessors used in the machines are not discussed: they are explained in terms of from sensors to the input of the DC controller PCB and from the output of the DC controller PCB to the loads.

The descriptions in this Service Manual are subject to change without notice for product improvement or other purposes, and major changes will be communicated in the form of Service Information bulletins.

All service persons are expected to have a good understanding of the contents of this Service Manual and all relevant Service Information bulletins and be able to identify and isolate faults in the machine."

Contents

Chapter 1 Specifications

1.1 Product Specifications	1- 1
1.1.1 Finisher Unit	1- 1
1.2 Names of Parts	1- 5
1.2.1 External View	1- 5
1.2.2 Cross Section	1- 6

Chapter 2 Functions

2.1 Basic Operation	2- 1
2.1.1 Basic Operation	2- 1
2.1.2 Overview of the Electrical Circuitry	2- 1
2.2 Feed Drive System	2- 3
2.2.1 Overview	2- 3
2.2.2 Construction of the Control System	2- 3
2.2.3 Paper Delivery Path	2- 6
2.3 Intermediate Process Tray Assembly	2- 11
2.3.1 Stack Job Offset	2- 11
2.3.2 Processing Tray Paper Stacking Operation	2- 12
2.3.3 Offset Operation	2- 12
2.3.4 Rear End Assist Operation	2- 13
2.3.5 Stack Delivery Operation	2- 14
2.4 Staple Operation	2- 15
2.4.1 Stapler Unit	2- 15
2.4.2 Shifting the Stapler Unit	2- 16
2.4.3 Stapling Operation	2- 18
2.5 Stack Tray Operation	2- 23
2.5.1 Tray Operation	2- 23
2.5.2 Shutter Operation	2- 25
2.6 Detecting Jams	2- 27
2.6.1 Detecting Jams (Finisher Unit)	2- 27
2.7 Power Supply	2- 29
2.7.1 Power Supply Route	2- 29
2.7.2 Protection Function	2- 29

Chapter 3 Installation

3.1 Making Pre-Checks	3- 1
3.1.1 Checking the Contents	3- 1
3.1.2 Installing the Accessories	3- 2
3.1.3 Selecting the Site of Installation	3- 3
3.2 Unpacking and Chacking the Components	3- 5
3.2.1 Unpacking	3- 5

3.3 Installation Procedure	3- 10
3.3.1 Preparing the Finisher for Installation	3- 10
3.3.2 Preparing the Host Machine for Installation.....	3- 10
3.3.3 Connecting to the Host Machine	3- 11
3.3.4 Checking the Height/Tilt	3- 12
3.4 Making Adjustments.....	3- 14
3.4.1 Adjusting the Height/Tilt.....	3- 14
3.4.2 Work After Making Checks/Adjustments	3- 16
3.5 Attaching the Labels etc.	3- 19
3.5.1 Attaching the Various Labels	3- 19

Chapter 4 Parts Replacement Procedure

4.1 External Covers	4- 1
4.1.1 Front Cover	4- 1
4.1.2 Rear Cover.....	4- 1
4.1.3 Left Upper Cover	4- 1
4.1.4 Upper Door.....	4- 2
4.1.5 Grate-shaped Upper Guide.....	4- 3
4.1.6 Grate-shaped Lower Guide	4- 5
4.2 Drive System	4- 9
4.2.1 Stapler.....	4- 9
4.2.2 Swing Unit.....	4- 10
4.3 Document Feeding System.....	4- 17
4.3.1 Process Tray Assembly	4- 17
4.3.2 Tray 1	4- 22
4.3.3 Tray 2	4- 24
4.3.4 Buffer Roller	4- 27
4.3.5 Return Roller	4- 29
4.3.6 Return Roller Unit.....	4- 35
4.4 Electrical System	4- 43
4.4.1 Finisher Controller PCB.....	4- 43
4.4.2 Static Charge Eliminator 1	4- 43
4.4.3 Static Charge Eliminator 2	4- 49

Chapter 5 Maintenance

5.1 User Maintenance	5- 1
5.1.1 User Maintenance (Finisher Unit)	5- 1
5.2 Maintenance and Inspection	5- 2
5.2.1 Periodically Replaced Parts.....	5- 2
5.2.2 Durables	5- 2
5.2.3 Periodical Servicing	5- 3
5.3 Adjustment.....	5- 4
5.3.1 Adjustment at Time of Parts Replacement.....	5- 4
5.4 Troubleshooting.....	5- 6
5.4.1 Error Code	5- 6
5.5 Outline of Electrical Components	5- 11
5.5.1 Sensors (Finisher Unit).....	5- 11

5.5.2	Microswitches (Finisher Unit)	5- 14
5.5.3	Solenoids (Finisher Unit)	5- 15
5.5.4	Motors (Finisher Unit)	5- 16
5.5.5	Clutches (Finisher Unit)	5- 18
5.5.6	PCBs (Finisher Unit)	5- 19
5.6	Variable Resistors (VR), Light-Emitting Diodes (LED), and Check Pins by PCB	5- 21
5.6.1	Overview	5- 21
5.6.2	Finisher Controller PCB	5- 21
5.7	Upgrading	5- 22
5.7.1	Upgrading (Finisher Unit)	5- 22
5.8	Service Tools	5- 30
5.8.1	Solvents and Oils	5- 30

Chapter 6 Error Code

6.1	Overview	6- 1
6.1.1	Overview	6- 1
6.2	User Error Code	6- 2
6.2.1	Staple is absent	6- 2
6.2.2	Stapler safety protection function activated	6- 2
6.2.3	Stack tray overstacking	6- 3
6.2.4	Stapler staple jam	6- 3
6.3	Service Error Code	6- 4
6.3.1	E500	6- 4
6.3.2	E505	6- 4
6.3.3	E514	6- 4
6.3.4	E519	6- 5
6.3.5	E530	6- 5
6.3.6	E531	6- 6
6.3.7	E532	6- 6
6.3.8	E535	6- 6
6.3.9	E537	6- 7
6.3.10	E540	6- 7
6.3.11	E542	6- 8
6.3.12	E584	6- 8
6.3.13	Temporary Functional Limit	6- 8

Chapter 1 Specifications

Contents

1.1 Product Specifications	1-1
1.1.1 Finisher Unit	1-1
1.2 Names of Parts	1-5
1.2.1 External View	1-5
1.2.2 Cross Section	1-6

1.1 Product Specifications

1.1.1 Finisher Unit

0004-7604

T-1-1

Item	Specifications	Remarks
Stacking method	Trays 1 and 2: by lifting tray	
Stacking orientation	Face down	
Stacking size	A3, A4, A4R, A5, A5R, B4, B5, B5R, postcard, 279 mm x 432 mm (11 x 17), LGL, LTR, LTRR, STMT, STMTR, elongation size, Envelope	Feed direction: 139.7 to 482.6 mm: cross feed direction: 98.4 to 330.2 mm; both maximum
Paper weight	64g/m ² to 250g/m ²	
Bins	2	
Modes	Non sort: Trays 1 and 2 Sort: Trays 1 and 2 Staple: Trays 1 and 2	
Stacking capacity	Tray 1: Non staple sort Large size: 74 mm high (500 sheets) Small size: 147 mm high (1000 sheets) Tray 2: Non staple sort Large size: 74 mm high (500 sheets) Small size: 147 mm high (1000 sheets) Tray 1: Staple sort Large size: 74 mm high (500 sheets)/30 sets Small size: 147 mm high (1000 sheets)/30 sets Tray 2: Staple sort Large size: 74 mm high (500 sheets)/30 sets	Equivalent of 80g/m ² paper.

Item	Specifications	Remarks
	Small size: 147 mm high (1000 sheets)/30 sets	
Mixed stacking capacity	Size mixing: 74 mm high (500 sheets)	
	Stapling: 74 mm high (500 sheets)/30 sets	
Stapling	By rotating cam	
Stapling capacity	Small size: 50 sheets(Thickness 5.7 mm or less)	Equivalent of 80g/m2 paper.
	Large size: 30 sheets	

Notes 1 : Stacking capacity is equivalent of 80g/m2 paper.

Notes 2 : Alignment may not be correct if 750 or more small-size sheets are stacked.

Notes 3 : Stacking capability is not guaranteed for mixed size stacking.

Paper Size Definition:

Large size (feed length of 216 to 432 mm):A3, A4R, B4, B5R, 279mm x 432mm (11 x 17), LGL, LTRR

Small size (feed length of 216 mm or less):A4, A5, A5R, B5, LTR, STMT, STMTR

T-1-2

Item	Specifications	Remarks
Staple supply	Special staple cartridge (5000 staples)	
Staple detection	Provided	0 to 40 remaining staples
Manual stapling	Not provided	
Stapling size	Front 1-point stapling (30 deg.) A4R, LGL, LTRR Front 1-point stapling (45 deg.) A3, B4, A4, B5, 279mm x 432mm (11 x 17), LTR Rear 1-point stapling (30 deg.) A4R, LGL, LTRR Rear 1-point stapling (45 deg.) A3, B4, A4, B5, 279mm x 432mm (11 x 17), LTR	

Item	Specifications	Remarks
	2-point stapling	
	A3, A4, B4, B5, 279mm x 432mm (11 x 17), LTR	
Paper detection	Provided	
Control panel	Not provided	
Display	Not provided	
Dimensions	W:536(649) x D:657 x H:928mm	If within parentheses, with the tray extended.
Weight	Approx. 36 kg	
Power supply	From host machine (24VDC/13VDC)	
Maximum power consumption	8 W or less during standby/70 W or less operating	

<Stapling Positions>

Front 1-point stapling (30deg.)
A4R, LGL and LTRR

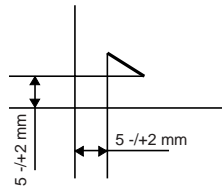

Front 1-point stapling (45deg.)
A3, A4, B4, B5,
279mm x 432mm (11x17) and LTR

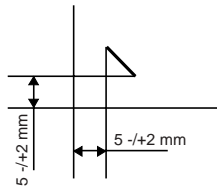

Rear 1-point stapling (30deg.)
A4R, LGL and LTRR

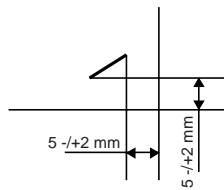

Rear 1-point stapling (45deg.)
A3, A4, B4, B5,
279mm x 432mm (11x17) and LTR

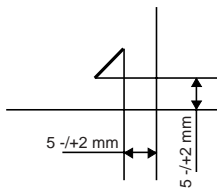

2-point stapling

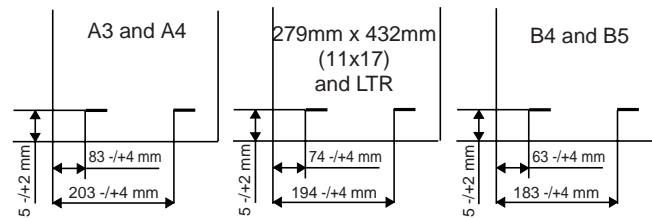

F-1-1

1.2 Names of Parts

1.2.1 External View

0004-7606

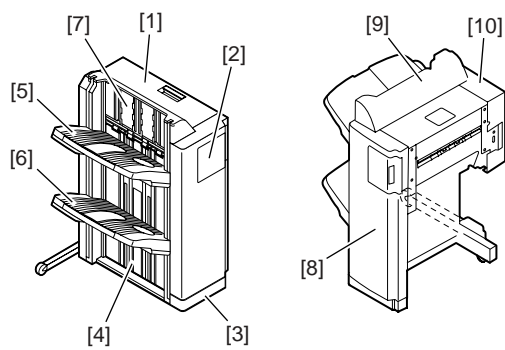

F-1-2

T-1-3

[1] Upper cover

[2] Front door

[3] Foot cover

[4] Grate-shaped lower guide

[5] Tray 1

[6] Tray 2

[7] Grate-shaped upper guide

[8] Front cover

[9] Left upper cover

[10] Rear cover

1.2.2 Cross Section

0004-7607

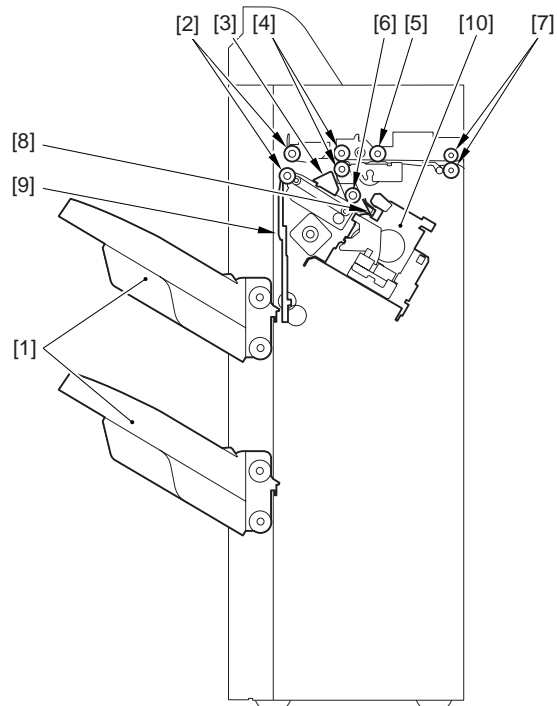

F-1-3

T-1-4

- | | |
|---------------------------|---------------------------|
| [1] Delivery tray | [6] Return roller |
| [2] Stack delivery roller | [7] Inlet roller |
| [3] Aligning plate | [8] Rear end assist guide |
| [4] 1st delivery roller | [9] Shutter |
| [5] Buffer roller | [10] Stapler |

Chapter 2 Functions

Contents

2.1 Basic Operation	2-1
2.1.1 Basic Operation	2-1
2.1.2 Overview of the Electrical Circuitry	2-1
2.2 Feed Drive System	2-3
2.2.1 Overview	2-3
2.2.2 Construction of the Control System	2-3
2.2.3 Paper Delivery Path	2-6
2.3 Intermediate Process Tray Assembly	2-11
2.3.1 Stack Job Offset	2-11
2.3.2 Processing Tray Paper Stacking Operation	2-12
2.3.3 Offset Operation	2-12
2.3.4 Rear End Assist Operation	2-13
2.3.5 Stack Delivery Operation	2-14
2.4 Staple Operation	2-15
2.4.1 Stapler Unit	2-15
2.4.2 Shifting the Stapler Unit	2-16
2.4.3 Stapling Operation	2-18
2.5 Stack Tray Operation	2-23
2.5.1 Tray Operation	2-23
2.5.2 Shutter Operation	2-25
2.6 Detecting Jams	2-27
2.6.1 Detecting Jams (Finisher Unit)	2-27
2.7 Power Supply	2-29
2.7.1 Power Supply Route	2-29
2.7.2 Protection Function	2-29

2.1 Basic Operation

2.1.1 Basic Operation

0003-9132

The finisher is designed to deliver copies arriving from its host machine, and its modes of delivery include simple stacking, job offset, and staple.

All operations involved in these modes are controlled by the finisher controller PCB, according to the appropriate commands from the host machine.

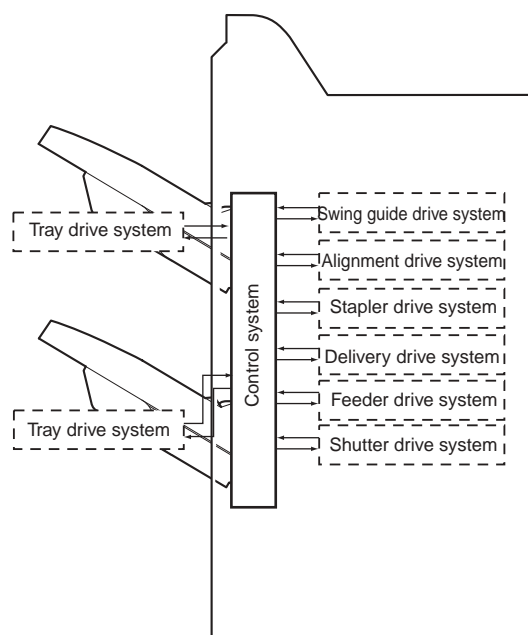

F-2-1

Memo: The term job offset refers to shifting each sorting job, separating a single stack into several stacks.

2.1.2 Overview of the Electrical Circuitry

0003-9133

The finisher's sequence of operation is controlled by the finisher controller PCB. The finisher controller PCB is a 16-bit microprocessor (CPU), and is used for communication with the host machine (serial) in addition to controlling the finisher's sequence of operations.

The finisher controller PCB responds to the various commands coming from the host machine through a serial communications line to drive solenoids, motors, and other loads. In addition, it communicates the finisher's various states (information on sensors and switches) to the host machine through a serial communications circuit.

The ICs used on the finisher controller PCB are designed for the following:

<IC101 (CPU)>

Controls sequence of operations.

Contains sequence programs.

<IC106 (EEP-ROM)>

Backs up adjustment values.

Backs up initial setting data.

<IC102 (communications IC)>

Communicates with the host machine.

<IC107 (regulator IC)>

Generates 5V.

<IC108 (regulator IC)>

Generates 3.3V.

The following figure shows the flow of signals between the finisher and the options controller.

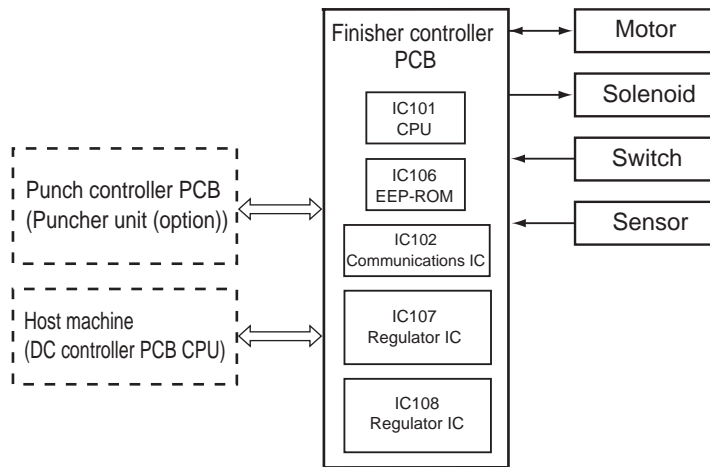

F-2-2

2.2 Feed Drive System

2.2.1 Overview

0004-4413

The finisher is designed to operate according to the commands from its host machine to deliver arriving copies to trays in the appropriate mode: simple stacking, job offset, stapling.

There are three delivery methods.

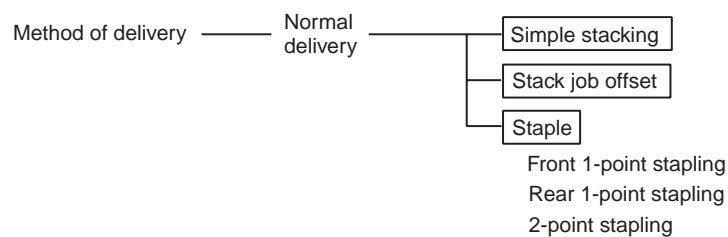

F-2-3

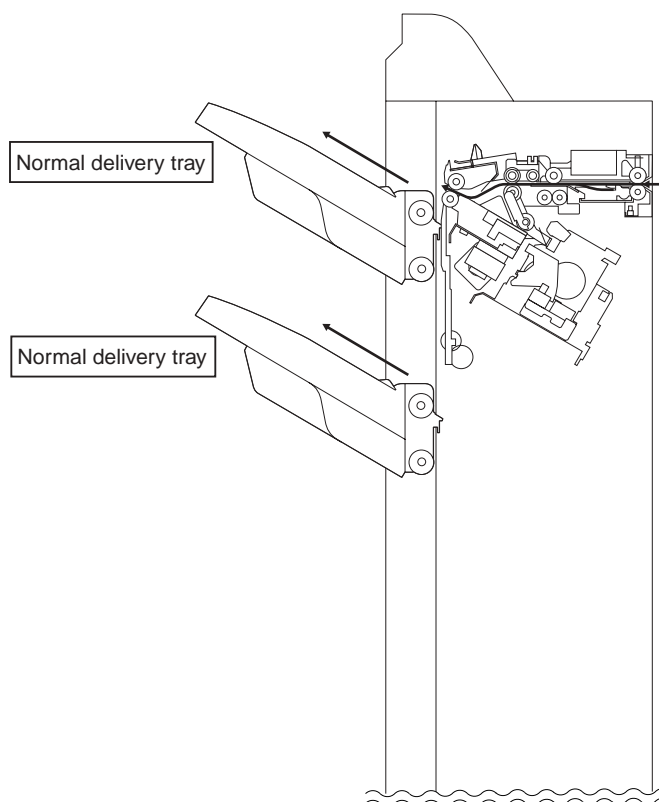

F-2-4

2.2.2 Construction of the Control System

0004-4426

The copy sent from the host machine is delivered to the ejection tray or processing tray according to the ejection type. Job offset or stapling is performed, according to the instruction from the host machine, for copy delivered to the

staple tray.

When ejecting from the processing tray, rear end assist guide is used in addition to the stack ejection roller to eject the stack.

The inlet motor (M31), stack ejection motor (M32), and rear end assist motor (M39) are step motors. These motors are rotated forward or backward by the microcomputer (CPU) in the finisher controller PCB.

The following two sensors are provided in the copy delivery path to detect the arrival or passing of copies.

Inlet sensor (PI33)

Delivery path sensor (PI34)

Also, each ejection tray has sensors to detect the presence of copy on the tray.

First tray paper sensor (PI42)

Second tray paper sensor (PI43)

If the copy does not reach or pass each sensor within prescribed time, the finisher controller PCB determines that the jam has occurred and stops the operation. Then it notifies the host machine that a jam has occurred. When all of the doors are closed after fixing the jam, the finisher checks whether copy is detected by any of the above two sensors (inlet sensor, delivery path sensor). If any of the sensors detects a copy, the finisher determines that the jam is not fixed and sends jam processing signal to the host machine once more.

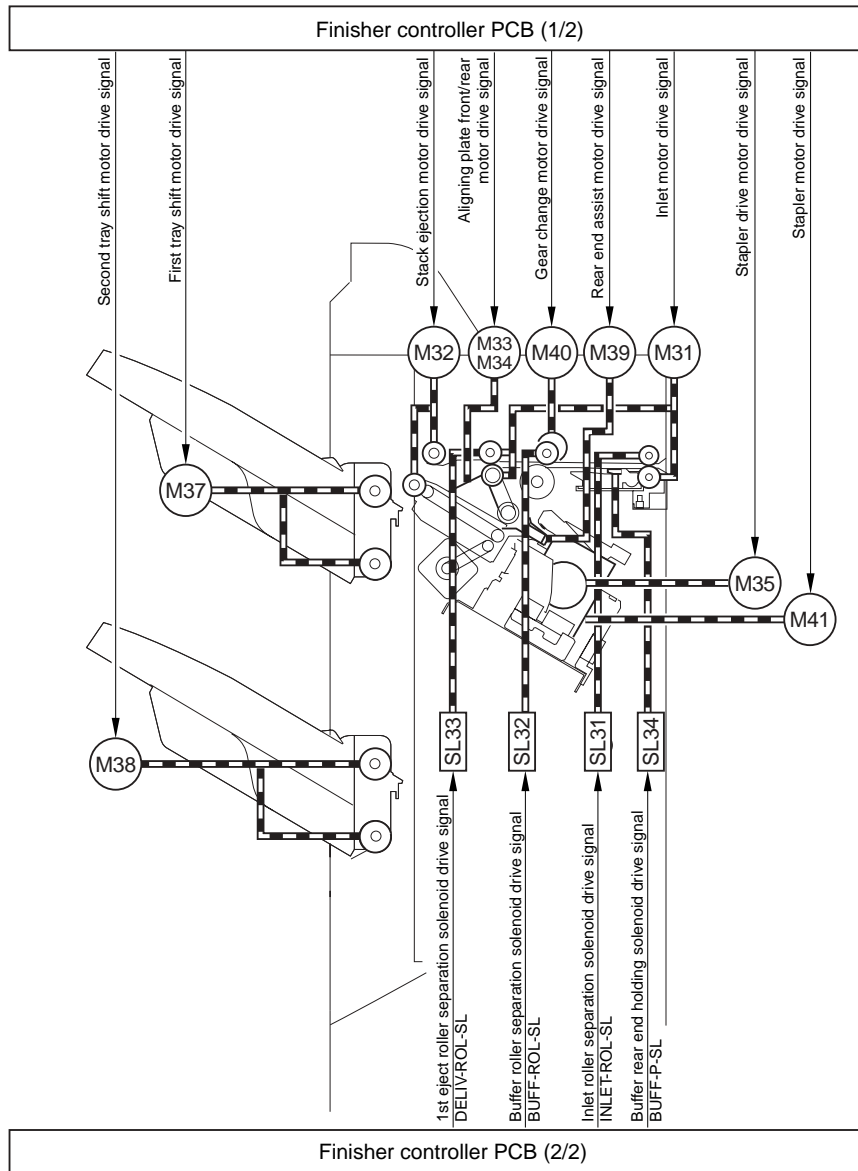

F-2-5

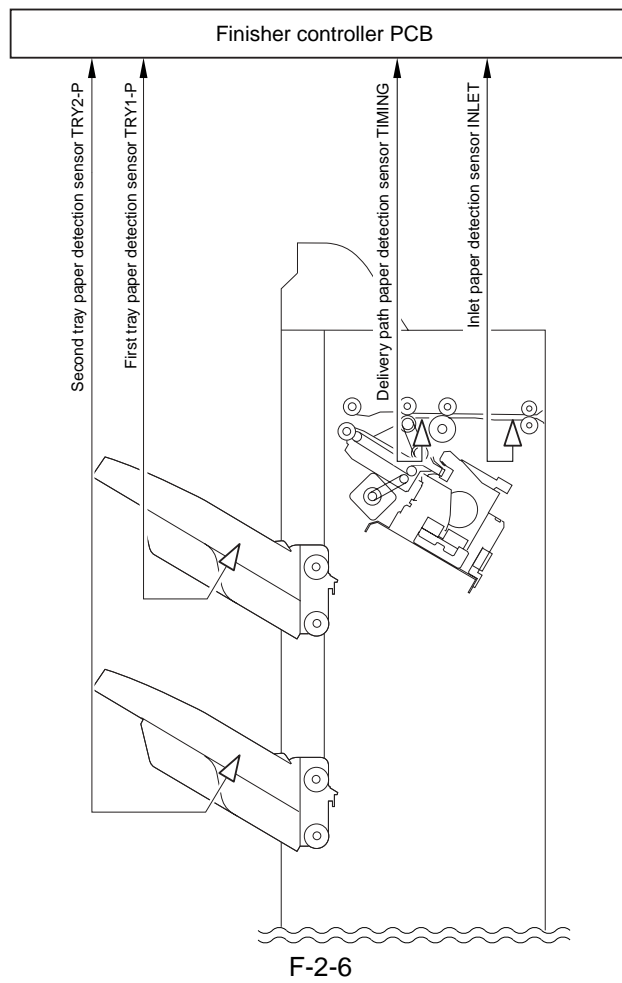

2.2.3 Paper Delivery Path

0004-4492

<Overview>

There are three ejection paths to tray 1 and 2 depending on the ejection processing.

<Straight Ejection>

When the equipment is set to non-sort, all copies are ejected through the following path.

Stack ejection roller

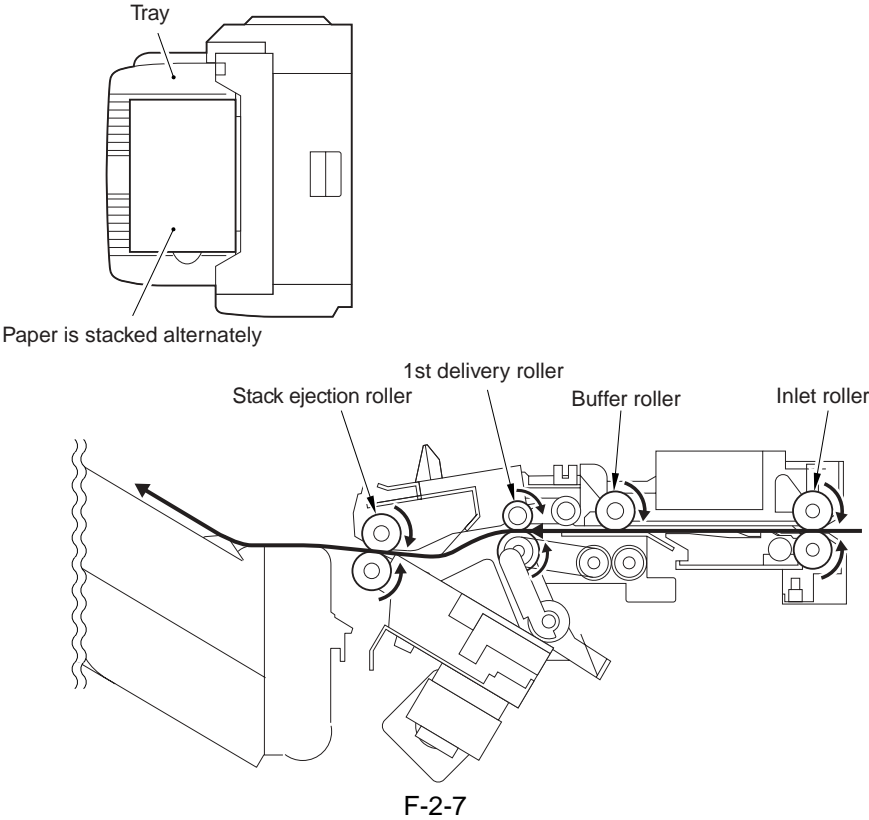

<Processing Tray Path>

This is the copy ejection path when the equipment is set to sort for paper size other than A4, B5, or LTR or when set to staple sort. Copies are delivered to the processing tray for aligning and stapling. Then they are ejected using the rear end assist.

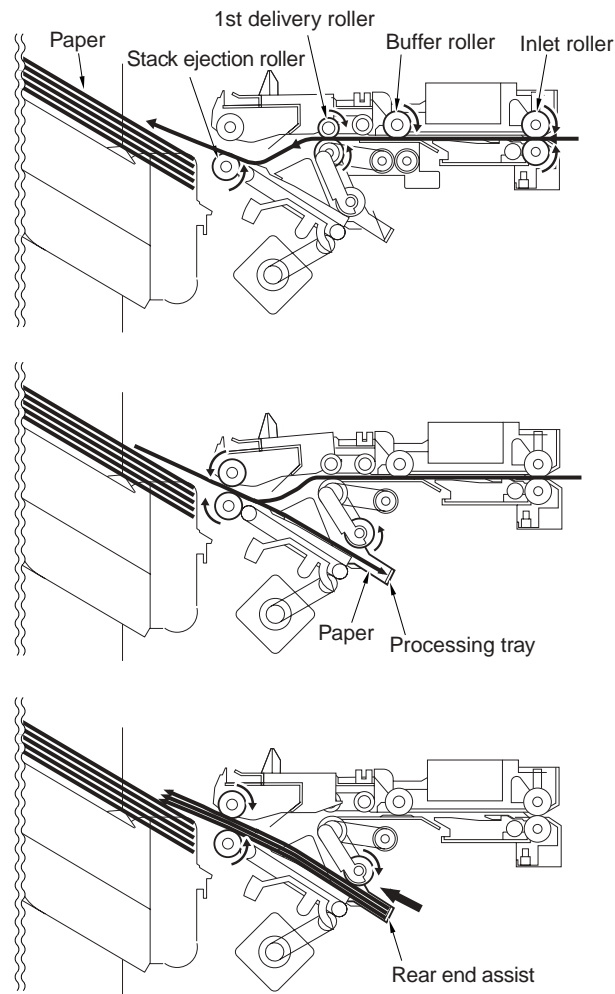

F-2-8

<Buffer/Processing Tray Path>

This is the copy ejection path when the equipment is set to sort for A4, B5, or LTR paper size. Feed two sheets of paper to buffer (two or three sheets if 2-point stapling). Then they are aligned and stapled in the processing tray and ejected. Even while stapling or offset is being performed, simultaneous stack ejection, which simultaneously ejects copies delivered to the buffer and post processed stack in the processing tray, is performed because copies are received continuously from the host machine. The stack delivered from the buffer is ejected to the processing tray and the stack processed in the processing tray is ejected to the tray.

Simultaneous stack ejection operation is described below for two A4 copies between stacks when the equipment is set to sort.

1) When the 1st paper reaches the switchback point, it is sent to the buffer unit and the rear end of the paper is held by the buffer guide.

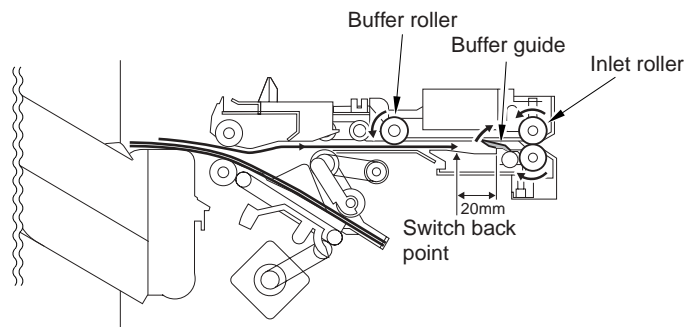

F-2-9

2) When the first copy is delivered to the buffer, the second copy is delivered from the host machine.

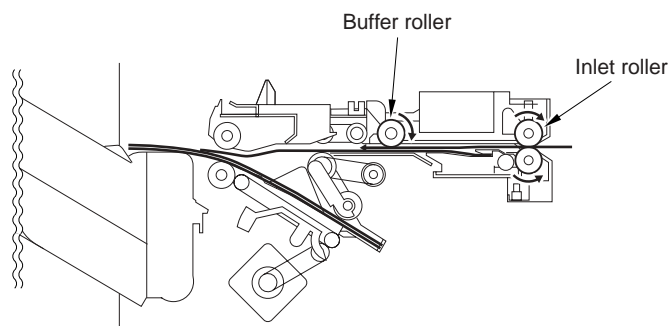

F-2-10

3) The first delivery roller descends and works together with the stack delivery roller to deliver the 1st and 2nd paper toward the processing tray. At the same time, the stack in the processing tray is delivered toward the delivery tray by the return roller and rear end assist guide.

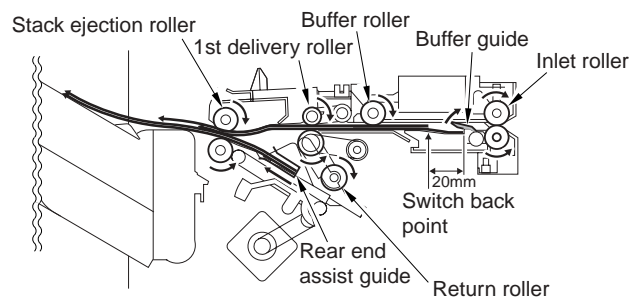

F-2-11

4) When the stack in the processing tray is delivered to the delivery tray and the rear end of the 1st and 2nd paper exits the 1st delivery roller, the 1st and 2nd paper are delivered toward the processing tray by the stack delivery roller and return roller.

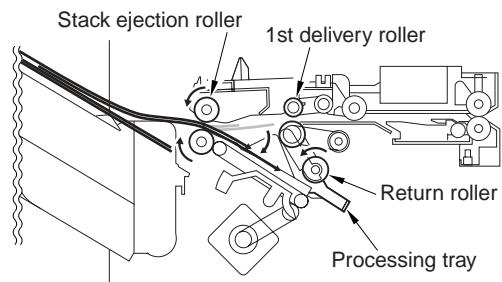

F-2-12

5) The 1st and 2nd paper delivered to the processing tray are aligned and then delivered to the delivery tray.

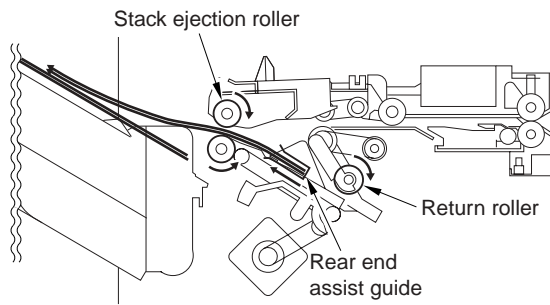

F-2-13

2.3 Intermediate Process Tray Assembly

2.3.1 Stack Job Offset

0003-4552

Job offset operation offsets paper stack to the front or rear when ejecting to sort the paper stack.

The forward/backward movement of the copy delivered to the processing tray is controlled by the front aligning plate and rear aligning plate.

The aligned copies are stapled or ejected according to the signal from the host machine.

When the power is turned on, the finisher controller PCB drives the aligning plate front motor (M33) and aligning plate rear motor (M34) to return the two aligning plates to home position.

The name and function of motors and sensors used by the stack job offset function are shown below.

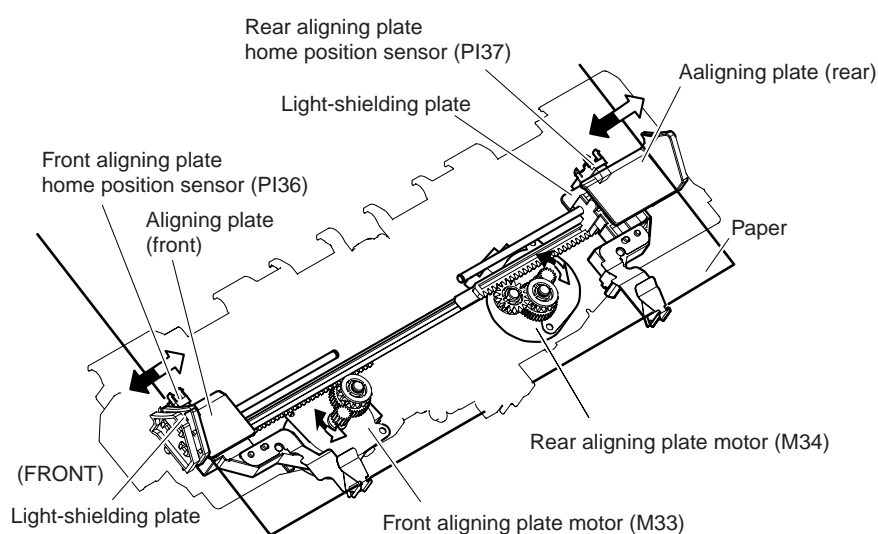

F-2-14

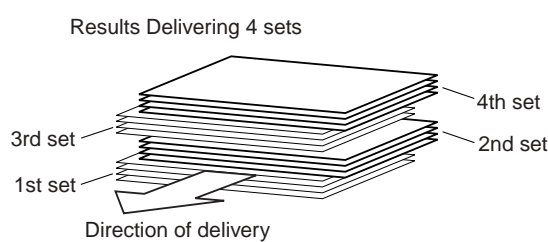

F-2-15

T-2-1

Motor	Function
Aligning plate front motor (M33)	Aligns paper in processing tray to the front
Aligning plate rear motor (M34)	Aligns paper in processing tray to the rear

Motor	Function
Swing motor (M36)	Moves the swing guide up/down
Rear end assist motor (M39)	Carry the stack end during stack ejection
	T-2-2
Sensor	Function
Swing guide HP sensor (PI35)	Detects the swing guide home position
Aligning plate front HP sensor (PI36)	Detects the aligning plate front home position
Aligning plate rear HP sensor (PI37)	Detects the aligning plate rear home position
Rear end assist HP sensor (PI39)	Detects the rear end assist home position

2.3.2 Processing Tray Paper Stacking Operation

0003-4553

When the rear end of the paper exits the 1st delivery roller, the paper is delivered to the processing tray by the stack delivery roller and return roller and then pushed against the processing tray stopper.

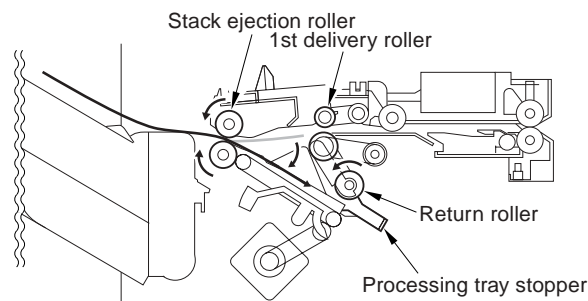

F-2-16

2.3.3 Offset Operation

0003-4554

Each sheet is pulled forward or backward using the front aligning plate and the rear aligning plate. The offset operation is performed each time a sheet is pulled onto the processing tray.

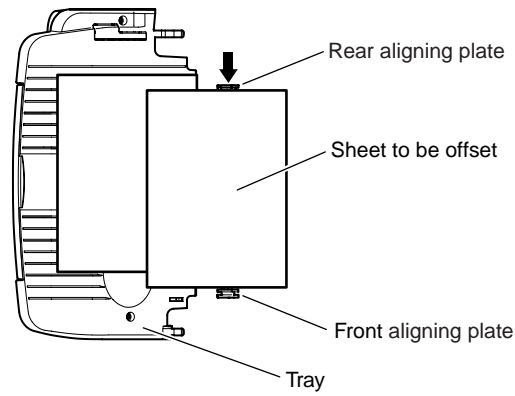

F-2-17

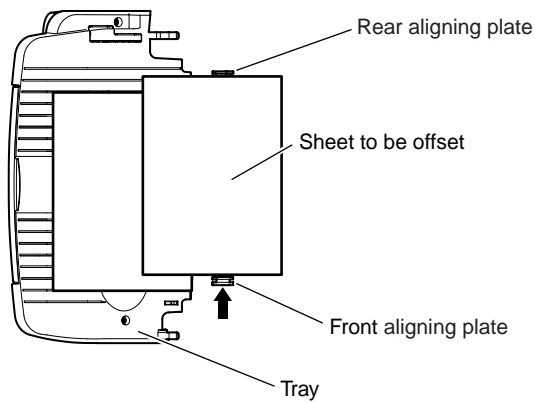

F-2-18

2.3.4 Rear End Assist Operation

0003-8730

In order to improve stacking performance when ejecting copies delivered to the processing tray, a rear end assist guide is used in addition to the stack ejection roller to support the rear end of the stack during stack ejection.

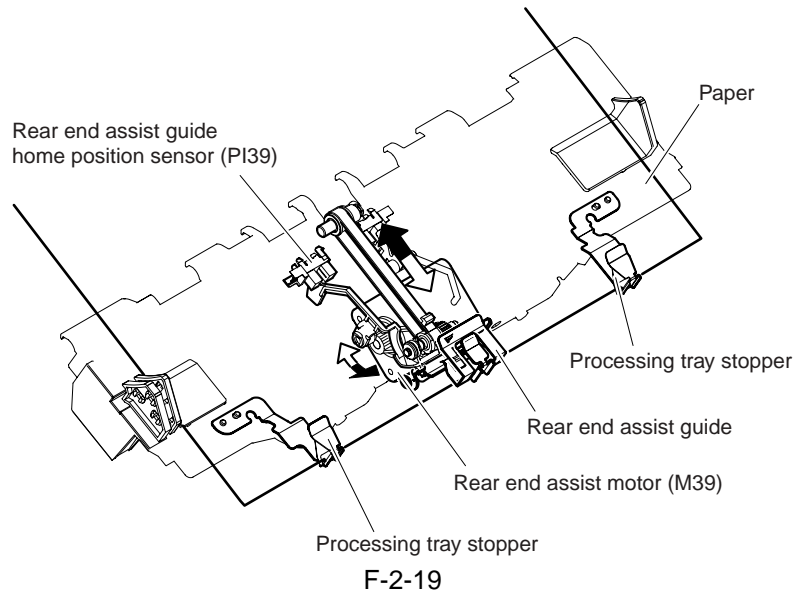

2.3.5 Stack Delivery Operation

0003-4555

The stack is ejected each time three large size sheets*1 or five small size sheets*2 are offset on the processing tray. The swing motor turns and the swing guide descends. This causes the upper/lower stack delivery rollers to hold the stack. The stack delivery motor turns the stack delivery roller and return roller. At the same time, the rear end assist guide is started by the rear end assist motor and the stack held by the stack delivery rollers is delivered in the ejection direction. The rear end assist guide stops once it reaches the prescribed position and returns to home position when the rear end assist motor is reversed. Then the stack delivery motor starts and ejects the stack with the upper/lower stack delivery rollers.

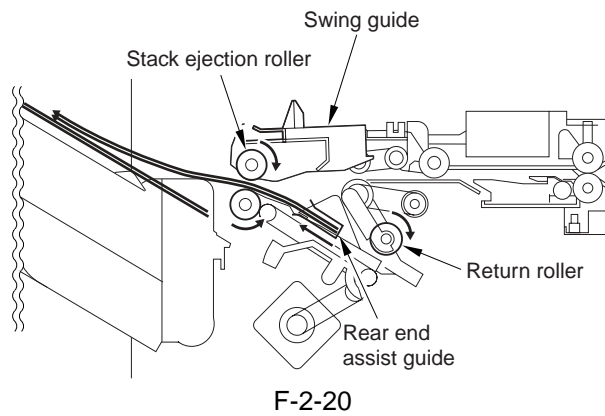

*1 Varies between 2 to 4 sheets depending on the number of paper. (Example: When the number of paper is 10, stacks are ejected in the order of 3 sheets, 3 sheets, and 4 sheets.)

*2 Varies between 2 to 6 sheets depending on the number of paper. (Example: When the number of paper is 7, stacks are ejected in the order of 5 sheets and 2 sheets.)

2.4 Staple Operation

2.4.1 Stapler Unit

0003-4557

The staple motor (M41) is used to perform stapling operation. This motor rotates the cam one turn for stapling. The home position of this cam is detected by the staple home position sensor (PI50).

The staple motor is rotated in the forward or reverse direction under the control of the macro computer (IC101) on the finisher controller PCB.

When the staple home position sensor is OFF, the finisher controller PCB rotates the staple motor in the forward direction until the sensor turns ON, allowing the staple cam to the original position.

The staple sensor (PI52) is used to detect presence/absence of a staple cartridge in the machine and presence/absence of staples in the cartridge.

The staple edging sensor (PI51) is used to determine whether staples are pushed up to the top of the staple cartridge. The finisher controller circuit does not drive the staple motor (M41) unless the staple safety switch (MS34) is ON. This assures safety in case where you happen to put your finger in the stapler.

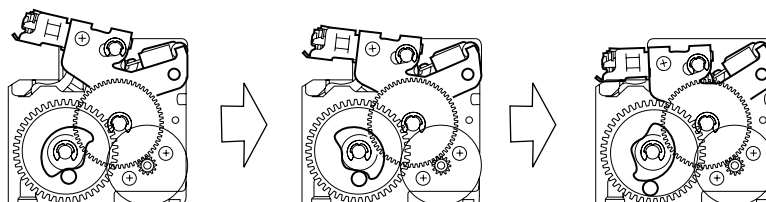

F-2-21

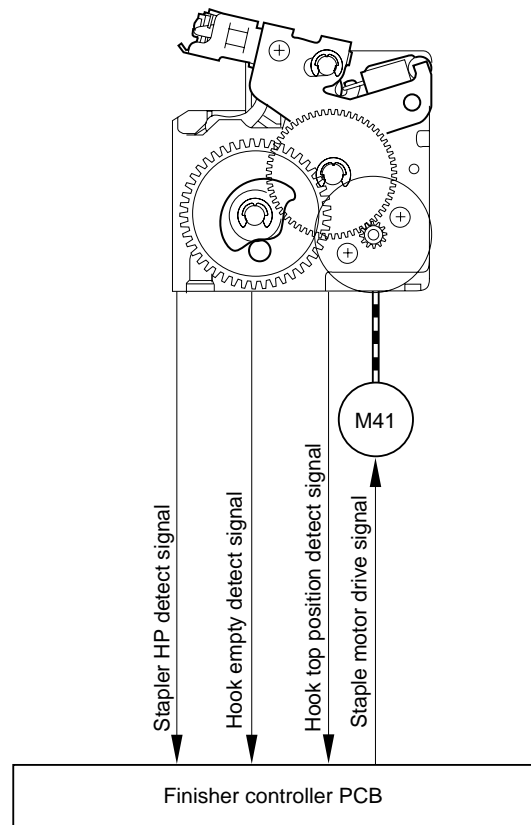

F-2-22

2.4.2 Shifting the Stapler Unit

0003-4558

The stapler unit is shifted by the stapler shift motor (M35). The home position is detected by the stapler shift home position sensor (PI40). When there is a staple command from the host machine, the stapler shifts to the staple ready position, which depends on the stapling position and paper size.

The stapler unit waits at the following points when staple mode is selected:

<Front 1-Point Stapling>

The position is the same as the stapling position.

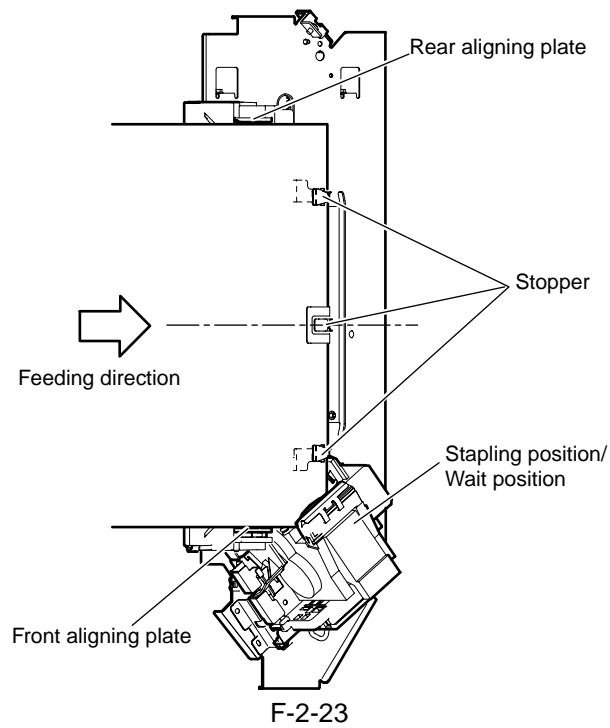

<Rear 1-Point Stapling>

The position is the same as the stapling position.

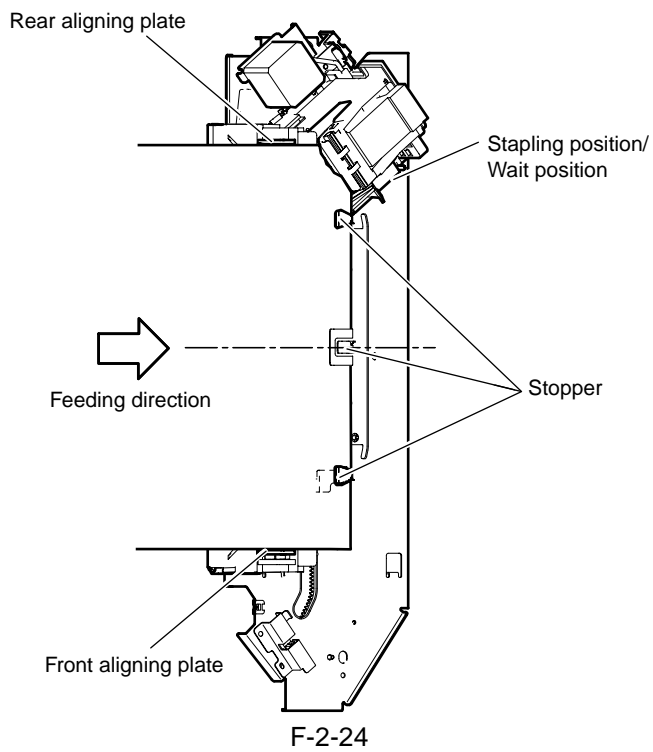

<2-Point Stapling>

The stapler waits at the paper front end side staple position. The stapling sequence is first near side and then far side.

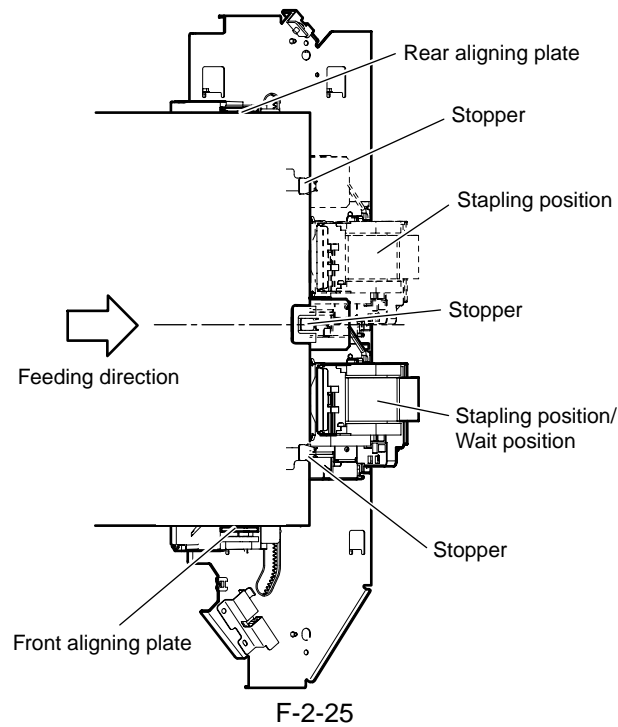

2.4.3 Stapling Operation

0003-4556

<Overview>

Stapling operation staples the prescribed number of copies with the stapler unit.

The staple position depends on the staple mode and paper size.

Whether the stapler unit is at home position or not is detected by the stapler shift home position sensor (PI40).

The stapler unit is equipped with a stapler alignment interference sensor (PI46). The staple motor (M41) operation is prohibited when the stapler alignment interference sensor (PI46) is ON. This is to prevent stapling at the stopper and damaging the stopper when the stapler shift motor (M35) is incorrectly adjusted.

When the power is turned on, the finisher controller PCB drives the stapler shift motor (M35) to return the stapler unit to home position. If the stapler unit is already at home position, it waits in that state.

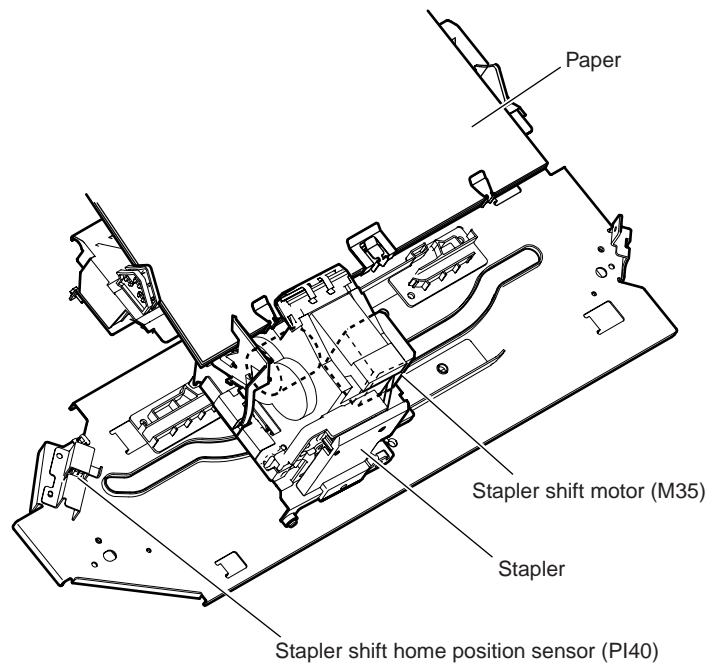

F-2-26

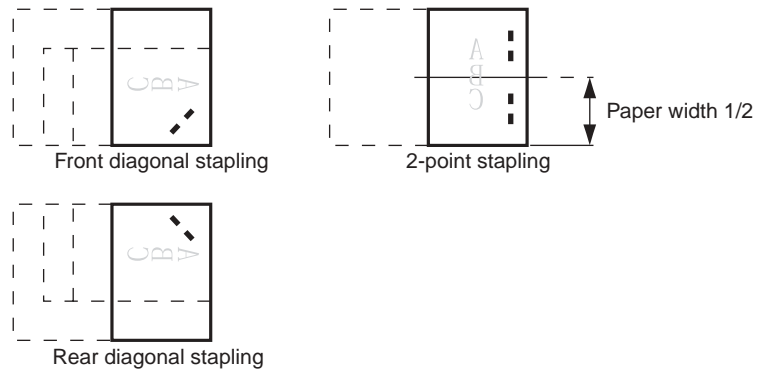

F-2-27

T-2-3

Sensor	Symbol	Connector	Function	Remarks
Stapler shift home position sensor	PI40	J721B-6	Detects the home position for the stapler moving back and forth.	-

Sensor	Symbol	Connector	Function	Remarks
Stapler alignment interference sensor	PI46	J717-3	Staple prohibited area detection	-
Staple home position sensor	PI50	J717-5	Detects the home position for the stapling operation.	In the stapler
Staple edging sensor	PI51	J717-6	Detects the staple top position.	In the stapler
Staple sensor	PI52	J717-7	Detects presence or absence of staples in the cartridge.	In the stapler

T-2-4

Function	Motor	Symbol	Remarks
Moves the stapler.	Stapler shift motor	M35	-
Performs stapling operation.	Staple motor	M41	-

<First Sheet>

The finisher controller PCB moves the stapler according to the specified stapling position.

When the rear end of the first sheet passes the 1st delivery roller, the finisher controller PCB stops the stack delivery motor (M32) and then rotates it in reverse. The stack delivery motor rotates the stack delivery roller and return roller and delivers the paper to the processing tray. The paper in the processing tray is detected by the processing tray paper sensor (PI38). When the paper is delivered to the processing tray, the swing motor (M36) starts and raises the swing guide. When the swing guide home position sensor (PI35) detects the rising of the swing guide, the swing guide motor stops and holds the swing guide at the raised position.

After the processing tray paper sensor detects the paper, the aligning motor (M33/M34) starts and aligns the paper.

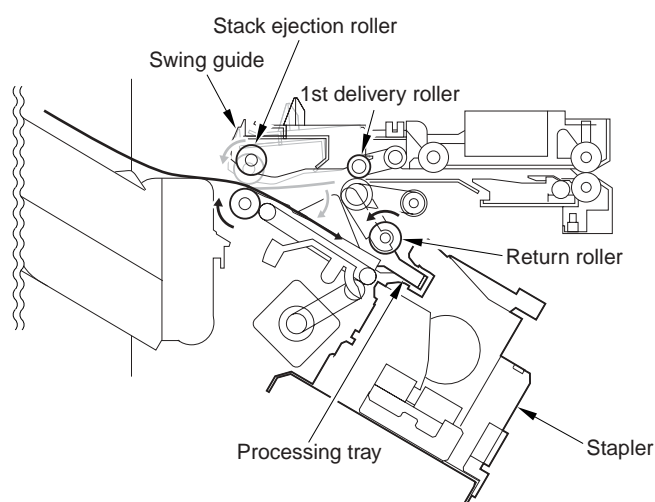

F-2-28

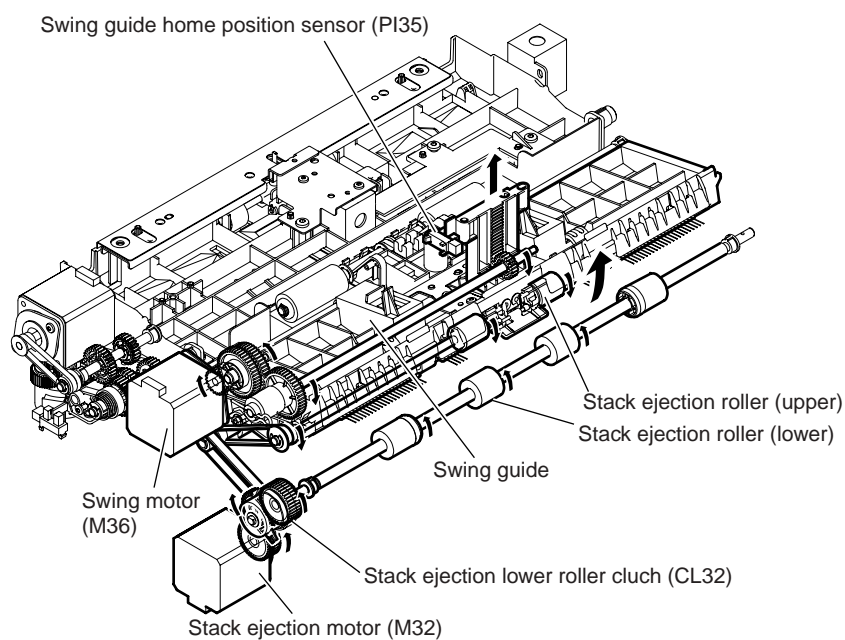

F-2-29

<Second and Subsequent Sheets>

The finisher controller PCB starts the swing motor (M36) and lowers the swing guide when the rear end of the 2nd paper passes the 1st delivery roller. The stack delivery motor is reversed. The stack delivery motor rotates the stack delivery roller (upper) and return roller and sends the paper to the processing tray. At this point, the stack delivery roller (lower) does not rotate because the stack ejection lower roller clutch (CL32) is disengaged. The paper in the processing tray is detected by the processing tray paper sensor (PI38).

When the paper is delivered to the processing tray, the swing motor (M36) starts and raises the swing guide. When the swing guide home position sensor (PI35) detects the rising of the swing guide, the swing guide motor stops and holds the swing guide at the raised position.

After the processing tray paper sensor detects the paper, the aligning motor (M33/M34) starts and aligns the paper.

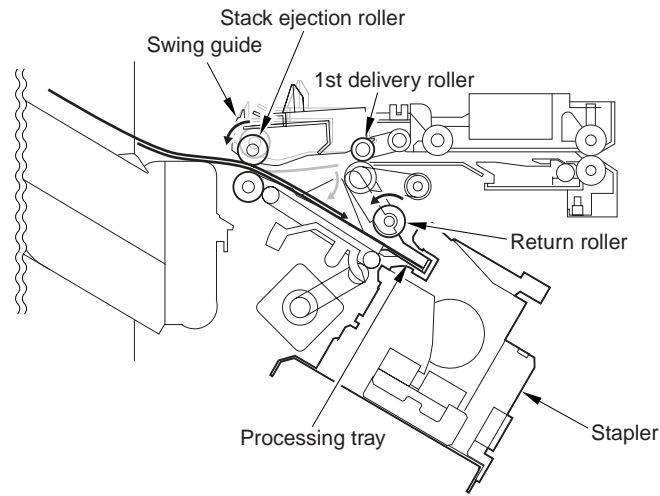

F-2-30

<Last Sheet>

When alignment of the last sheet completes, the finisher controller PCB moves the aligning plate to alignment position with the aligning motor (M33/M34) (with the paper held with the aligning plate). Then the finisher controller PCB staples at the specified staple position.

After stapling, the finisher controller PCB starts the swing motor (M36) and lowers the swing guide. Then the stack is ejected by the stack delivery roller, return roller, and rear end assist guide.

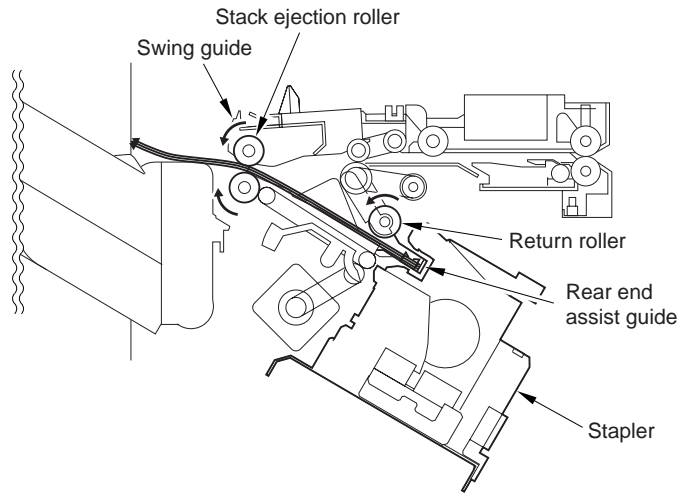

F-2-31

2.5 Stack Tray Operation

2.5.1 Tray Operation

0003-4561

This equipment has two delivery trays. The upper tray is called tray 1 and the lower tray is called tray 2. The upper and lower tray can move up and down independently.

The trays are moved up and down by the tray 1 shift motor (M37) and tray 2 shift motor(M38).

Tray 1 paper sensor (PI42) and tray 2 paper sensor (PI43) are provided to detect the presence of the paper stacked on the tray.

The home position of tray 1 is detected by the paper surface sensor (PI41) and the home position of tray 2 is detected by the tray 2 paper surface sensor (PI48). The home position is the top surface of the paper if papers are already stacked on the tray, or the position where the edge of the tray is detected if no paper is stacked. When the power is turned on, the finisher controller PCB drives the tray 1 shift motor (M37) and tray 2 shift motor (M38) to return the tray to home position. If the tray is already at home position, it is moved out of the home position once and then returned to the home position once more. If both tray 1 and tray 2 are at home position, this is performed for tray 1 and then for tray 2. If the tray specified by the host machine is tray 2, the finisher controller PCB shifts the tray so that tray 2 is at delivery port.

When paper is stacked on the tray, a prescribed number of pulses drive tray 1 shift motor (M37) or tray 2 shift motor (M38) and the tray is lowered. Then the tray returns to home position to prepare for the next stack.

The upper and lower limits of the tray are detected by three area sensors (PS981, PS982, and PS983) on tray 1 and tray 2 shift area sensor PCB. The finisher controller PCB stops driving the tray 1 shift motor (M37) and tray 2 shift motor (M38) when it detects the upper or lower limit of the tray. Also, the ON/OFF combinations of the area sensors (PS981, PS982, PS983) are used to detect over-stacking according to the stack height for large size and mixed stacking. The following figure shows the items detected with the ON/OFF combinations of the area sensors (PS981, PS982, PS983).

The finisher controller PCB stops supplying +24V to the tray 1 shift motor (M37) and stops the finisher operation when tray 1 switch (MS33) turns ON.

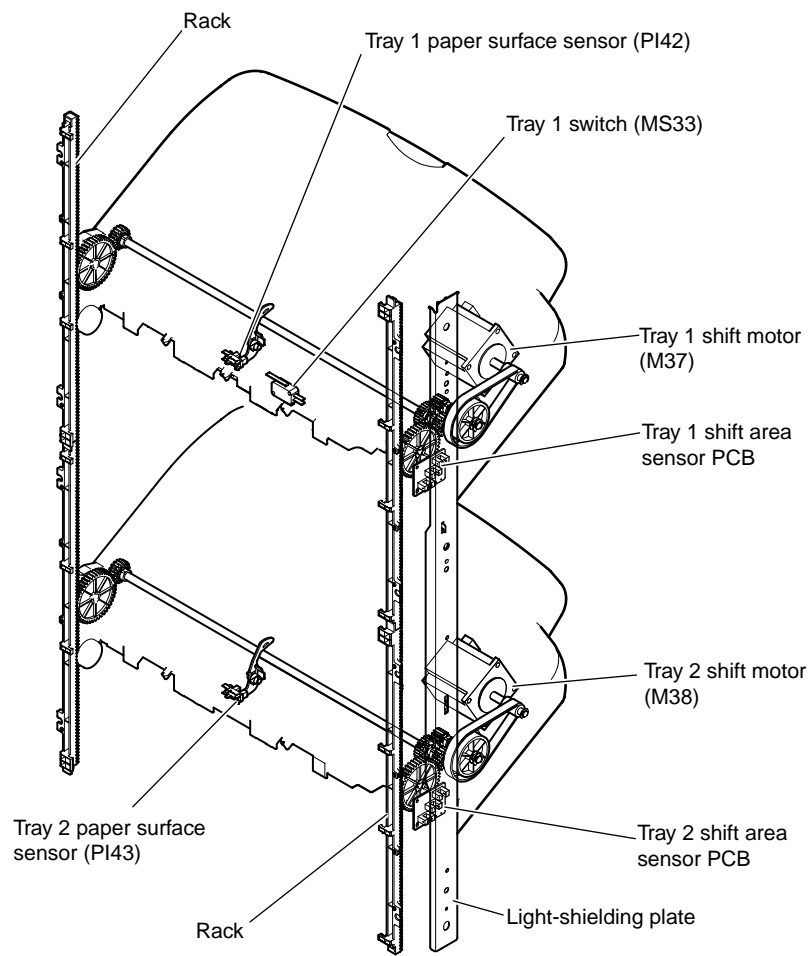

F-2-32

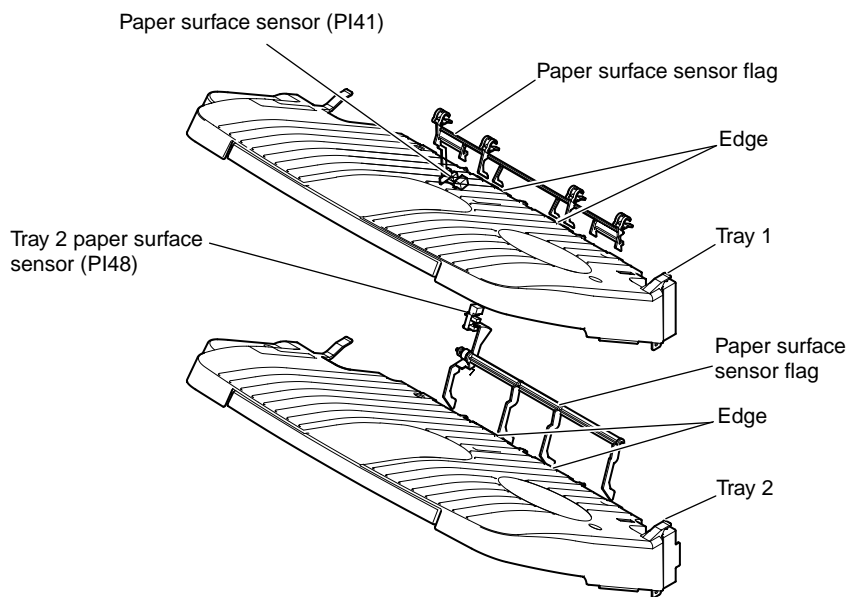

F-2-33

T-2-5

Detected items	Tray 1 shift area sensor PCB		
	Area sensor 1(PS983)	Area sensor 2(PS982)	Area sensor 3(PS981)
Tray 1 upper limit	OFF	OFF	OFF
Stack count 500 sheet limit exceeded	ON	ON	OFF
Stack count 1000 sheet limit exceeded	ON	OFF	OFF
Tray 1 lower limit	ON	OFF	ON

T-2-6

Detected items	Tray 2 shift area sensor PCB		
	Area sensor 1(PS983)	Area sensor 2(PS982)	Area sensor 3(PS981)
Tray 2 upper limit	OFF	ON	OFF
Stack count 500 sheet limit exceeded	ON	ON	OFF
Stack count 1000 sheet limit exceeded	ON	OFF	OFF
Tray 2 lower limit (finisher)	OFF	OFF	OFF
Tray 2 lower limit (saddle finisher)	OFF	OFF	ON

* The symbol for the area sensor of each PCB is same because tray 1/tray 2 shift area sensor PCBs are the same board.

2.5.2 Shutter Operation

0003-8734

When tray 1 passes the delivery section with paper already stacked, the stacked paper may get caught by the delivery section. A shutter is provided at the delivery section to prevent this. The shutter closes when tray 1 passes the delivery section. This is performed even when no paper is stacked.

When the shutter clutch (CL31) and stack ejection lower roller clutch (CL32) are ON, the shutter moves up (close) when the stack ejection motor (M32) turns forward and moves down (open, delivery enabled) when the motor turns backward.

The open/close of the shutter is detected by the shutter home position sensor (PI45).

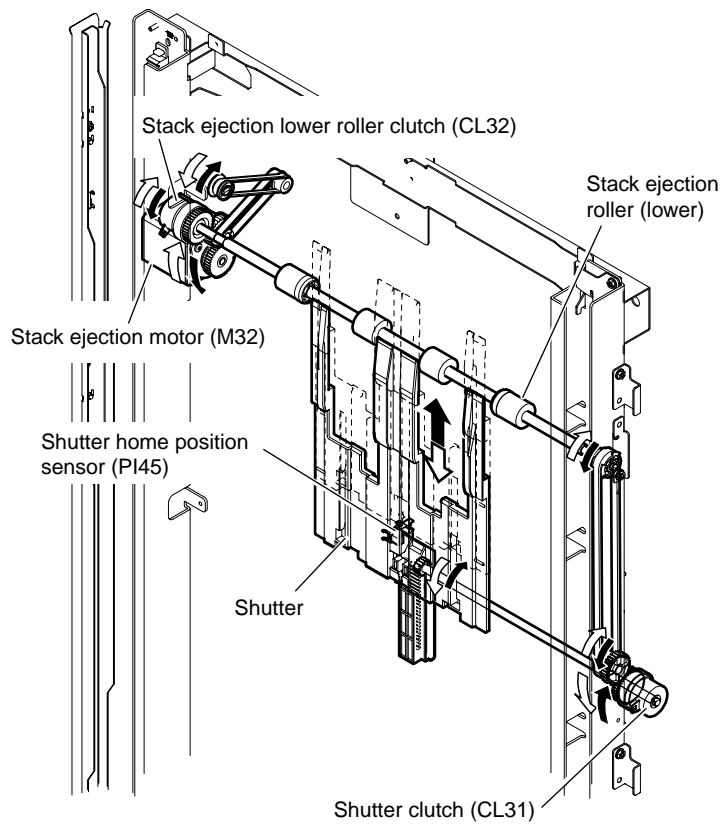

F-2-34

2.6 Detecting Jams

2.6.1 Detecting Jams (Finisher Unit)

0003-4562

The following sensors are used to detect the presence of paper and to determine that paper is delivered properly.

- Inlet sensor (PI33)
- Delivery sensor (PI34)

A jam is identified by checking whether paper is present at each sensor at the timing programmed in the memory of the microcomputer (CPU) on the finisher controller PCB.

When the CPU identifies a jam, it suspends the finisher's delivery operation and informs the host machine DC controller of the presence of a jam. When all doors are closed after the paper jam is removed, the finisher checks whether paper is detected by the above two sensors (inlet sensor and tray 1 delivery sensor). If the sensors detect paper, the finisher determines that paper jam is not completely removed and sends a jam removal signal to the host machine once more.

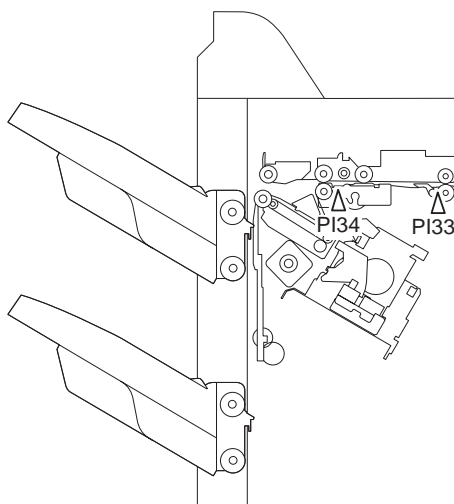

F-2-35

T-2-7

Jam Type	Sensor	Jam Condition	Code
Inlet sensor delay	PI33	When the inlet sensor (PI33) does not detect paper after a prescribed time (distance) has elapsed since receiving a delivery signal from the host machine.	1001
Inlet sensor stationary	PI33	When paper does not exit the inlet sensor (PI33) after delivering for a prescribed time (distance) after the inlet sensor (PI33) detected paper.	1101

Jam Type	Sensor	Jam Condition	Code
Feed path sensor delay	PI34	When the feed path sensor (PI34) does not detect paper after prescribed time (distance) has elapsed since the inlet sensor (PI33) detected paper.	1004
Feed path sensor stationary	PI34	When paper does not exit the feed path sensor (PI34) after delivering for a prescribed time (distance) after the delivery sensor (PI34) has detected paper.	1104
Timing	PI33	When the inlet sensor (PI33) detects paper before receiving a delivery signal from the host machine.	1200
Staple	PI50	When the staple motor (M41) is rotated forward, the staple home position sensor (PI5) does not turn back ON after a prescribed time has elapsed after it goes OFF, and the staple home position sensor (PI50) becomes ON within prescribed time after the staple motor (M41) is rotated backward. * Replace the stapler unit when the staple home position sensor (PI50) becomes faulty since it is built in the stapler unit.	1500
Power-on	PI33,PI34	When paper is detected by the inlet sensor (PI33) or the delivery path sensor (PI34) during power on.	1300
Door open	PI31,PI32, MS31	When the upper cover open/close sensor (PI31), front cover open/close sensor (PI32), or the front cover close detect switch (MS31) detects that the cover is opened.	1400

2.7 Power Supply

2.7.1 Power Supply Route

0004-4503

When the power of the host machine is turned on, 13VDC and 24VDC are supplied from the host machine to the Finisher controller PCB. 24VDC is used to drive motors and solenoids, and 13VDC is converted into 5VDC by the regulator IC (IC107) on the Finisher controller PCB and used to drive the sensors on the PCB. Furthermore, it is converted into 3.3VDC by the regulator IC (IC108) on the Finisher controller PCB and used to drive the ICs on the PCB. If the Puncher unit, which is an optional, is installed, they are supplied to the punch controller PCB as well.

24VDC power for motor drive is shut down when the front cover switch (MS31) is open. This is not applicable for 24VDC power for the optional puncher unit.

A block diagram of power supply is shown below.

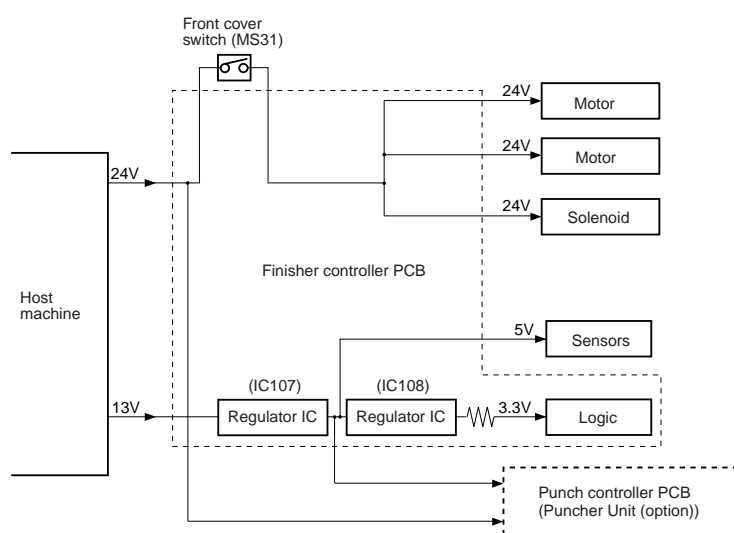

F-2-36

2.7.2 Protection Function

0004-4508

The 24 VDC for motor and solenoid drive has a fuse or motor driver with over-current protection function for over-current protection.

Chapter 3 Installation

Contents

3.1 Making Pre-Checks	3-1
3.1.1 Checking the Contents.....	3-1
3.1.2 Installing the Accessories	3-2
3.1.3 Selecting the Site of Installation.....	3-3
3.2 Unpacking and Chacking the Components	3-5
3.2.1 Unpacking	3-5
3.3 Installation Procedure.....	3-10
3.3.1 Preparing the Finisher for Installation.....	3-10
3.3.2 Preparing the Host Machine for Installation	3-10
3.3.3 Connecting to the Host Machine	3-11
3.3.4 Checking the Height/Tilt	3-12
3.4 Making Adjustments	3-14
3.4.1 Adjusting the Height/Tilt.....	3-14
3.4.2 Work After Making Checks/Adjustments	3-16
3.5 Ataching the Labels etc.	3-19
3.5.1 Attaching the Various Labels	3-19

3.1 Making Pre-Checks

3.1.1 Checking the Contents

0003-1754

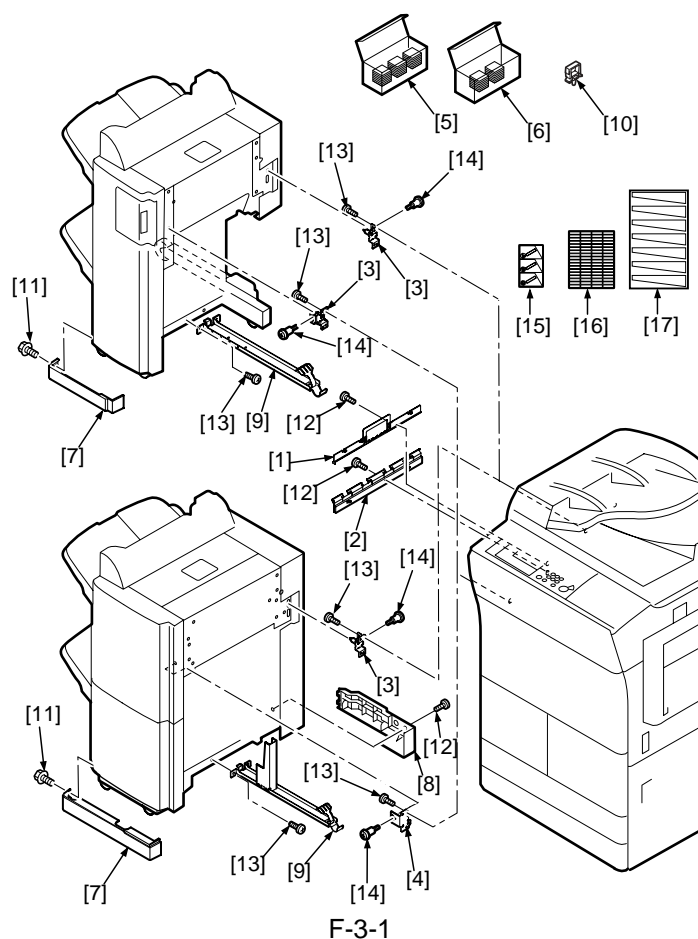

F-3-1

T-3-1

<Finisher-R1>

[1]Inlet guide upper	1 pc.
[2]Inlet guide lower	1 pc.
[3]Fixing plate (FC5-4196)	2 pc.
[5]Staple cartridge	1 pc. (3 blocks)
[7]Front foot cover	1 pc.

<Saddle Finisher-R2>

[1]Inlet guide upper	1 pc.
[2]Inlet guide lower	1 pc.
[3]Fixing plate (FC5-4196)	1 pc.
[4]Fixing plate (FC5-4976)	1 pc.
[5]Staple cartridge	1 pc. (3 blocks)

[9]Rail	1 pc.	[6]Saddle staple cartridge	1 pc. (2 blocks)
[10]Cable clamp	1 pc.	[7]Front foot cover	1 pc.
[11]Screw (RS tightening; M3x8)	1 pc.	[8]Rear foot cover	1 pc.
[12]Screw (tapping; M4x12)	2 pc.	[9]Rail	1 pc.
[13]Screw (binding; M4x6)	6 pc.	[10]Cable clamp	1 pc.
[14]Screw (stepped; M4)	2 pc.	[11]Screw (RS tightening; M3x8)	1 pc.
[15]Tray label	1 pc.	[12]Screw (tapping; M4x12)	3 pc.
[16]Settings label	1 pc.	[13]Screw (binding; M4x6)	6 pc.
		[14]Screw (stepped; M4)	2 pc.
		[15]Tray label	1 pc.
		[16]Settings label	1 pc.
		[17]Bookmaking label	1 pc.

3.1.2 Installing the Accessories

0003-1756

If you are installing the machine and other accessories at the same time, install the host machine, and then install the accessories in the following order:

- 1.Side paper deck (see its Installation Procedure)
- 2.Finisher [1], [2] (See "Preparing the Finisher for Installation" herein)
- 3.Additional finisher tray [3] (see its Installation Procedure)
- 4.Puncher unit [4] (see its Installation Procedure)
- 5.Connection with the host machine (See the instructions herein or "Connecting to the Host Machine" in the "Puncher Unit Installation Procedure")

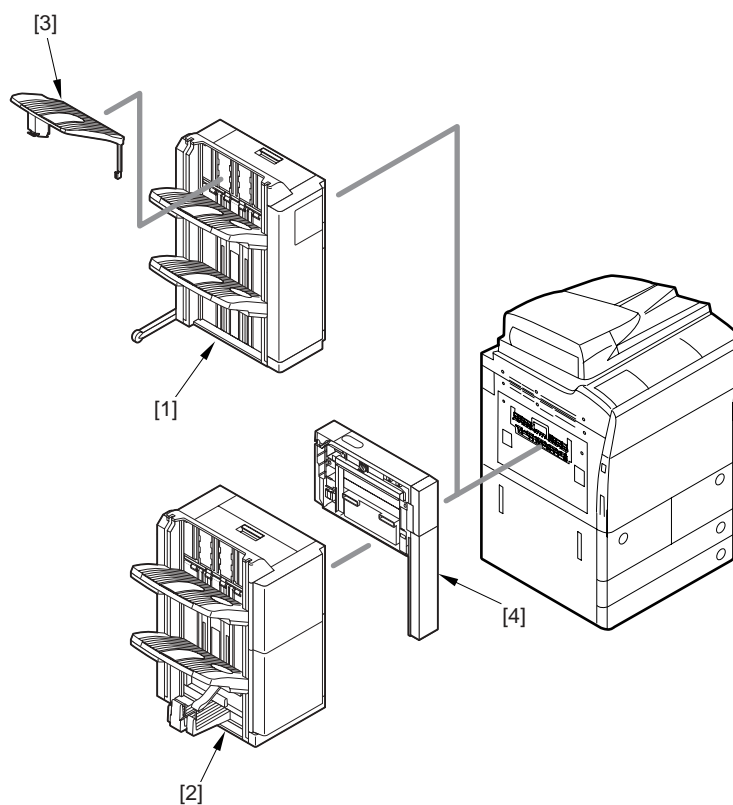

F-3-2

⚠ Before installing an accessory, be sure to go through the following on the host machine in the order indicated:

1. Turn off the host machine's control panel power switch.
2. Turn off the host machine's main power switch.
3. Disconnect the host machine's power plug (from the power outlet).

3.1.3 Selecting the Site of Installation

0003-1758

Select the site of installation, making sure that there will be enough space for work (e.g., handling paper). Be sure also that there will be no gap between the finisher and its host machine.

<Finisher-R1>

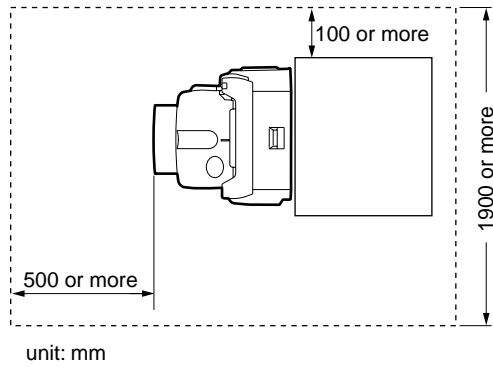

F-3-3

<Saddle Finisher-R2>

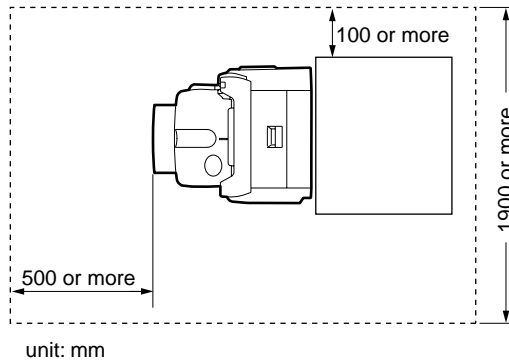

F-3-4

⚠ Install both the finisher and its host machine on a level floor without any step. Otherwise, the machines may suffer faults in paper movement.

3.2 Unpacking and Chacking the Components

3.2.1 Unpacking

0003-1759

Memo: The machine is packed using tape and cushioning material to protect against vibration and shock during transit. Be sure to remove them before starting to install the machine. (It is a good idea to store away the removed tape and cushioning material for possible relocation of the machine, e.g., to a new site or for repairs.)

1) Take out the accessory box and the attachments from the shipping box.

⚠At this point, do not remove the 4 cushioning materials (Styrofoam) from the finisher. Otherwise, you would likely deform some areas of the machine.

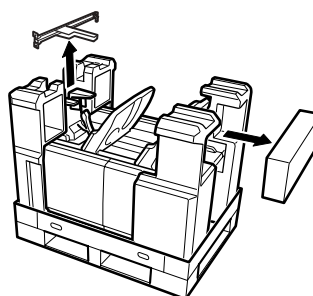

F-3-5

2) Lift the finisher together with its cushioning base (Styrofoam). Be sure to work in a group of 2 persons.

⚠If you shift up the finisher on its side, you would likely deform or damage the machine. Moreover, in the case of the Saddle Finisher-R2, force applied to the front cover [1] can deform the hinge.

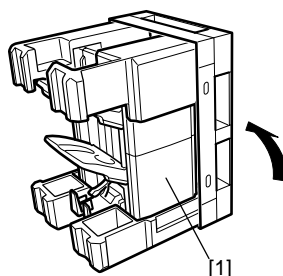

F-3-6

3) Remove the cushioning material (Styrofoam) from the upper cover.

4) Slightly lift the front and rear casters, and remove the cushioning material (Styrofoam). Be sure to shift up the finisher by holding the upper left cover [1] (gray area).

⚠ The finisher is rather heavy. Be sure to work in a group of 2 persons. Particularly when moving it over a step on the floor, be sure to take full care not to let it tumble over.

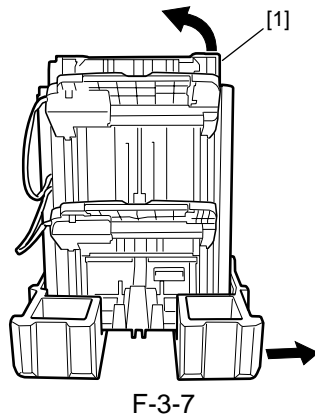

5) Remove the tape used on the outside of the finisher.

6) Remove the cushioning material [1] (Styrofoam) of the tray.

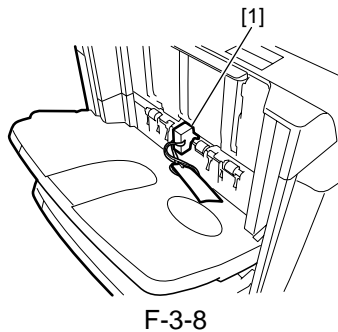

7) Remove the fixing screw [1], and remove the 2 tray fixings [2].

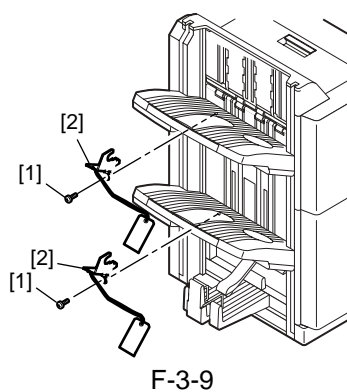

8) In the case of the Finisher-R1, open the front door [1]. In the case of the Saddle Finisher-R2, open the front cover [2].

<Finisher-R1>

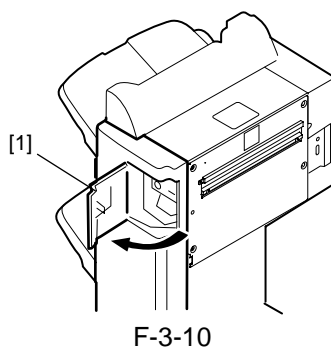

<Saddle Finisher-R2>

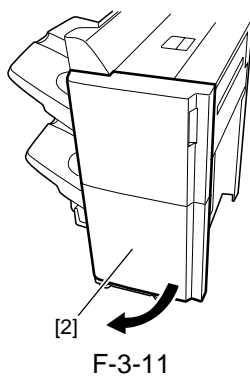

9) Remove the tape and the cushioning material [1] (Styrofoam) from the stapler.

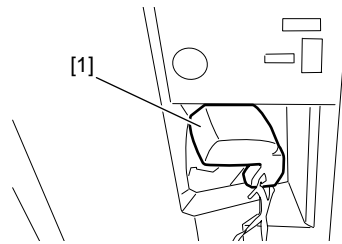

F-3-12

10) In the case of the Finisher-R1, close the front door. In the case of the Saddle Finisher-R2, go to the next step while keeping the front cover open.

A. Removing the Stitcher Fixing Member (only for the Saddle Finisher-R2)

1) Slide out the stitcher unit [1] to the front, and remove the tape.

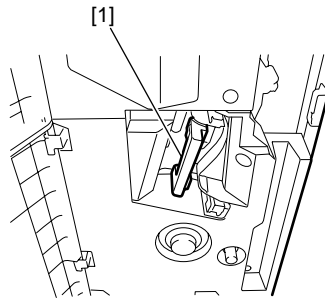

F-3-13

2) Remove the screw [1], and remove the stitcher fixing member [2].

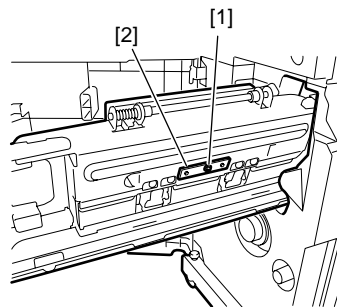

F-3-14

3) Put the stitcher back in and close the front cover.

B. Removing the Folding Roller Releasing Plate (only for the Saddle Finisher-R2)

Memo: The releasing plate must be mounted to prevent roller deformation, as otherwise occurring when the machine is not used for a long time. Once you have removed the plate and its fixing screws, it is a good idea to store them away for future use.

- 1) Remove the 7 screws [1], and detach the lower right cover [2].

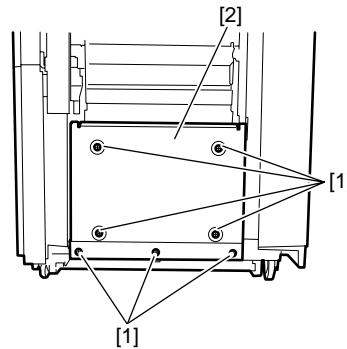

F-3-15

- 2) Remove the fixing screw [1], and detach the releasing plate (front) [2].

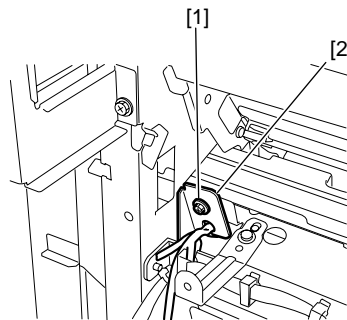

F-3-16

- 3) Remove the fixing screw [1], and detach the releasing plate (rear) [2].

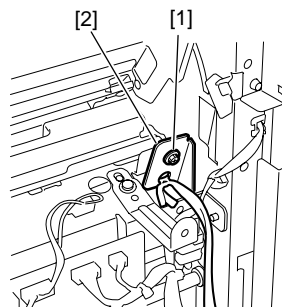

F-3-17

- 4) Mount the lower right cover you have removed using the 7 screws.

3.3 Installation Procedure

3.3.1 Preparing the Finisher for Installation

0003-1760

<Finisher-R1>

1) Mount the rail [1] to the finisher using 2 screws [2] (binding; M4x6).

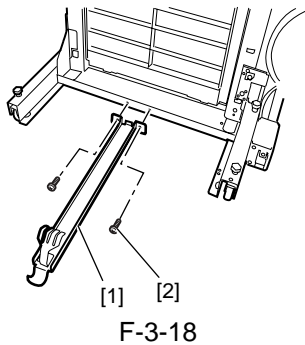

<Saddle Finisher-R2>

1) Mount the rail [1] to the finisher using 2 screws [2] (binding; M4x6).

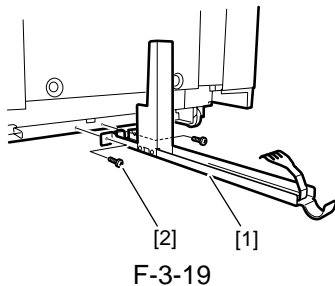

3.3.2 Preparing the Host Machine for Installation

0003-1762

▲ Be sure to mount the inlet guide and the fixing plate before connecting the finisher to its host machine.

1) If a delivery tray is found on the delivery assembly of the host machine, remove it.

2) Remove the 3 screws [1], and detach the left cover [2] of the host machine.

3) Cut off the 2 face covers [3] of the left cover using nippers; then, mount the left cover to the machine.

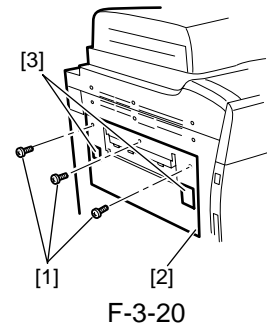

4) Slide the inlet guides upper [1] and lower [2] to the delivery assembly of the host machine; then, fix it in place using a screw [3] (1 pc. each; tapping; M4x12).

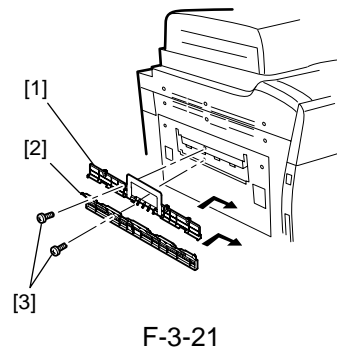

5) Mount the front fixing plate [1] and the rear fixing plate [2] using 2 screws each [3] (binding; M4x6).

▲ If you are installing a puncher unit, be sure to mount the fixing plate that comes with the unit as instructed in the Puncher Unit Installation Procedure.

<Finisher-R1>

Use FC5-4196 for both fixing plates [1] and [2].

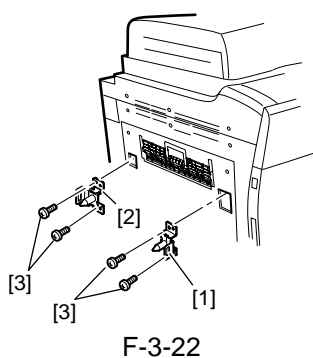

<Saddle Finisher-R2>

Use FC5-4976 for the fixing plate [1] and FC5-4196 for the fixing plate [2].

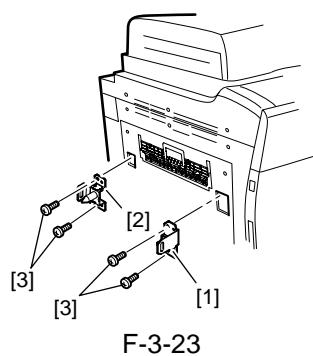

3.3.3 Connecting to the Host Machine

0003-1765

⚠ Check to make sure that the host machine is off, and its power plug is not connected to the power outlet.

1) Make the connection by matching the pin found on the fixing plate (rear) of the host machine against the hole in the finisher.

⚠ Check to be sure that there is no gap between the finisher and its host machine.

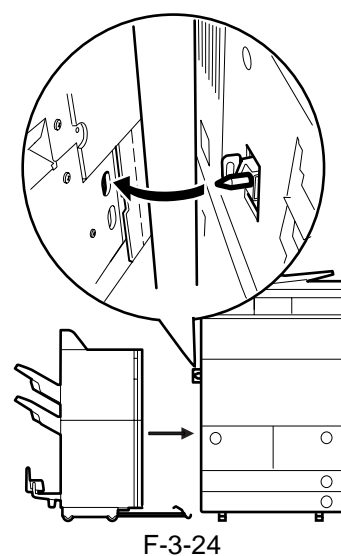

2) Remove the screw [1], and detach the upper rear cover (small) [2] of the finisher.

3) Fix the fixing plate (rear) of the host machine in place to the finisher using a stepped screw [3] (M4).

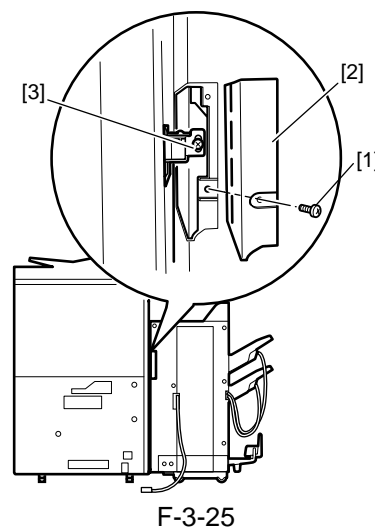

4) In the case of the Finisher-R1, open the front door [1] and remove the 3 screws [2], then detach the front cover [3].

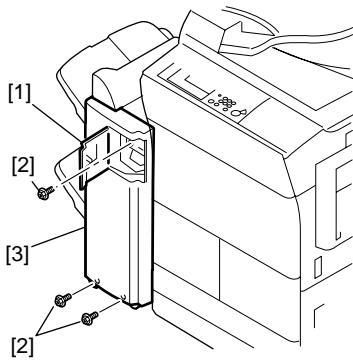

F-3-26

5) In the case of the Saddle Finisher-R2, open the front cover [1].

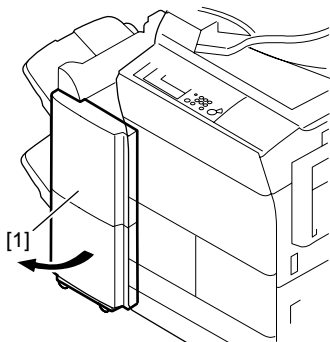

F-3-27

6) Fix the fixing plate [1] (front) of the host machine in place to the finisher [3] using a stepped screw [2] (M4). (The figure shows a Finisher-R1.)

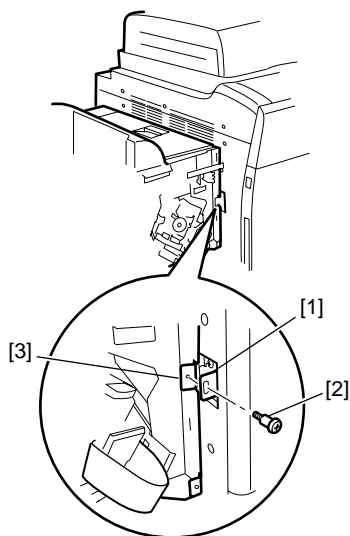

F-3-28

7) In the case of the Saddle Finisher-R2, close the front cover. In the case of the Finisher-R1, do not attach the front cover until you have adjusted the height/tilt.

3.3.4 Checking the Height/

Tilt

0003-1767

⚠ Depending on the condition of the floor of the site of installation, you may need to adjust the height or the tilt of the finisher. A discrepancy in the height or tilt of the finisher can well lead to frequency jams. Check the height/tilt as follows, and make adjustments as necessary. (If you are installing a puncher unit, be sure to make adjustments by referring to the Puncher Unit Installation Procedure.)

1) Check the height of the finisher and its host machine. Check to make sure that the difference in height between the top cover of the finisher and the delivery cover of the host machine is 53 ± 2 mm. Take measurements at 2 locations at the front and the rear; then, check to make sure that the difference between the front and the rear is 1.5 mm or less.

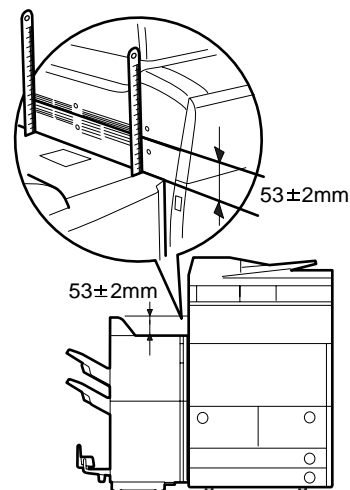

F-3-29

2) Check the tilt of the finisher and its host machine.

Check to make sure that the gap between the upper cover of the finisher and the delivery cover of the host machine is 3 ± 1.5 mm. Take measurements at 2 locations (front and rear), and check to make sure that the gap at the front and the rear is 1.5 mm or less. Also, check to be sure that the gap between the finisher and its host machine is parallel from top to bottom when viewed from the front.

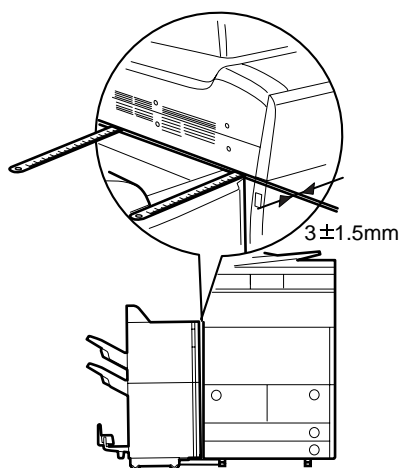

F-3-30

3) If the height/tilt is correct, end the installation work by referring to "Work After Making Checks/Adjustments." If the height/tilt is not correct, see the instructions in "Adjusting the Height/Tilt."

3.4 Making Adjustments

3.4.1 Adjusting the Height/Tilt

0003-1769

⚠ If the height or the tilt of the finisher and the host machine is not as indicated, go through the following steps to make an appropriate correction:

A. Preparing for Adjustment

<Finisher-R1>

⚠ In the case of the Finisher-R1, you will need to remove its auxiliary ring and rear foot cover. Be sure to remove the auxiliary ring with the finisher and its host machine intact, thus preventing the machine from tumbling over.

- 1) If you need to adjust the height at the rear, remove the 4 screws [1], and detach the auxiliary plate [2].
- 2) Remove the 2 screws [3], and detach the left rear foot cover [4].

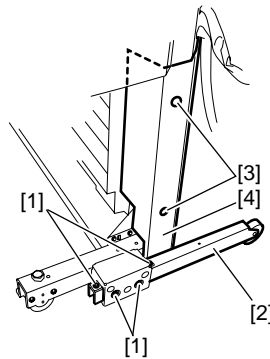

F-3-31

- 3) From the back of the removed front cover, remove the fixing screw, and detach the pliers [1].

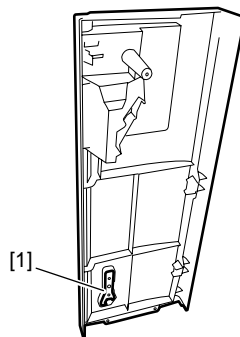

F-3-32

<Saddle Finisher-R2>

- 1) Open the front cover; then, from the back of the front cover, remove the fixing screw, and detach the pliers [1].

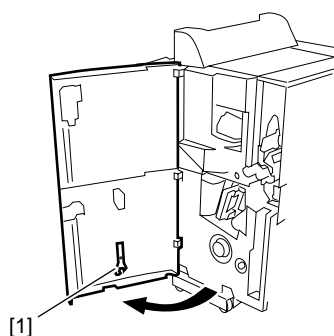

F-3-33

B. Adjusting the Height

- 1) Loosen the 2 fixing screws [1] each of the casters at the front and rear of the finisher pickup side.
- 2) If you want to increase the height of the finisher, turn the adjusting bolt [2] in the direction of arrow A of the figure. (A full turn of the adjusting bolt will increase the height of the finisher by 1.75 mm.) Refer to the index in the caster area when adjusting the height. Perform this for both front and rear casters.
- 3) If you want to decrease the height of the finisher, turn the adjusting bolt [2] in the direction of arrow B. (A full turn of the adjusting bolt will decrease the height of the finisher by 1.75 mm.) Refer to the index in the caster area when adjusting the height. Perform this for both front and rear casters.

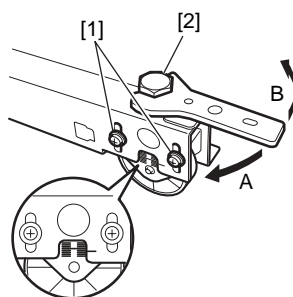

F-3-34

C. Adjust the Tilt

- 1) Loosen the 2 fixing screws [1] 2 each on the front and rear casters of the finisher delivery side.
- 2) If you want to decrease the gap between the finisher and its hot machine, turn the adjusting bolt [2] in the direction of arrow A. (A full turn will increase the height of the finisher by 1.75 mm.)
- 3) If you want to increase the gap between the finisher and its host machine, turn the adjusting bolt [2] in the direction of arrow B. (A full turn of the adjusting bolt will decrease the height of the finisher by 1.75 mm.) Adjust the tilt by referring to the index in the caster area. Perform this for both front and rear casters.

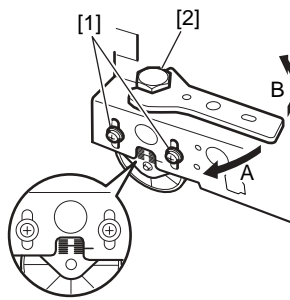

F-3-35

D. Making Checks After Making Adjustments

- 1) Check to see that the difference in height between the finisher and the host machine and the tilt are as indicated once again. Otherwise, start over the foregoing steps.
- 2) When done, tighten the 2 fixing screws [1] each on the casters.
- 3) To prevent loosening of the adjusting bolts after installation (as by relocation), turn each adjusting bolt [2] about 90 deg in the direction of the arrow. Do not turn them more than 90 deg; excess tightening can displace positions.

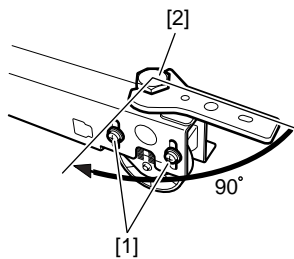

F-3-36

- 4) Fit the pliers in place to the back of the front cover using a screw.
- 5) End the installation work by referring to the instructions in "Work After Making Checks/Adjustments."

3.4.2 Work After Making Checks/Adjustments

0003-1770

<Finisher-R1>

- 1) If you removed the auxiliary ring, attach the left rear foot cover; then, adjust the auxiliary rail to suit needs of the user, and mount it in place using 4 screws.
- 2) Mount the front cover to the finisher using 3 screws.
- 3) Mount the rear upper cover (small) to the finisher using a screw.
- 4) Mount the front foot cover [1] using a screw [2] (RS tightening ; M3x8).

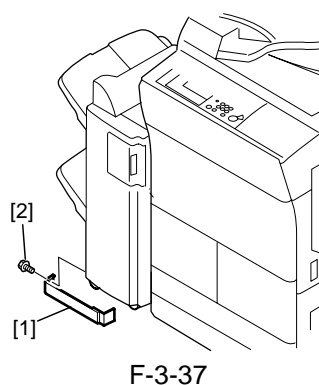

F-3-37

- 5) Connect the finisher and the host machine using the interface cable [1].
- 6) Fix the cable clamp [2] to the host machine, and route the interface cable [1] through it.

⚠ When connecting the interface cable, be sure to turn off the host machine and disconnect its power plug from the power outlet before starting the work. Otherwise, you may suffer an electric shock.

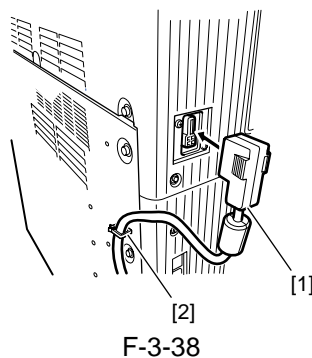

F-3-38

<Saddle Finisher-R2>

- 1) Mount the rear upper cover (small) to the finisher using a screw.
- 2) Mount the front foot cover [1] using a screw (RS tightening; M3x8) [2].
- 3) Align the rear foot cover claw [3] with the rear cover and mount the rear foot cover [4] with a screw (tapping; M4x12) [5].

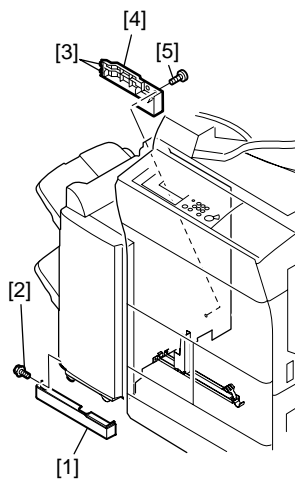

F-3-39

- 4) Connect the finisher and its host machine with the interface cable [1].
 - 5) Fit the cable clamp [2] to the host machine, and route the interface cable [1] through it.
-

⚠ When installing the interface cable, be sure to turn off the host machine and disconnect its power plug from the power outlet. Otherwise, you can suffer an electric shock.

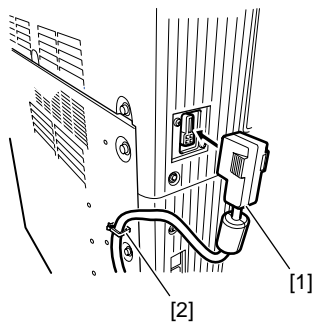

F-3-40

3.5 Attaching the Labels etc.

3.5.1 Attaching the Various Labels

0003-1771

- 1) Attach the tray label [1] to the tray as indicated.
- 2) Attach the settings label [2] within the frame of the tray label to suit the user habit of the user.
- 3) In the case of the Saddle Finisher-R2, attach the Bookmaking label [3] to the saddle tray as shown.

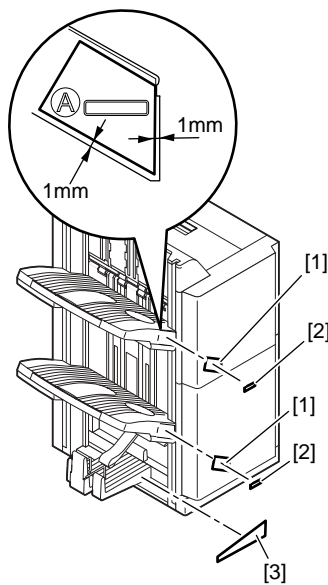

F-3-41

Chapter 4 Parts

Replacement Procedure

Contents

4.1 External Covers	4-1
4.1.1 Front Cover.....	4-1
4.1.1.1 Removing the Front Cover	4-1
4.1.2 Rear Cover.....	4-1
4.1.2.1 Removing the Rear Cover	4-1
4.1.3 Left Upper Cover.....	4-1
4.1.3.1 Removing the Front Cover	4-1
4.1.3.2 Removing the Rear Cover	4-2
4.1.3.3 Removing the Left Upper Cover	4-2
4.1.4 Upper Door.....	4-2
4.1.4.1 Removing the Front Cover	4-2
4.1.4.2 Removing the Rear Cover	4-3
4.1.4.3 Removing the Left Upper Cover	4-3
4.1.4.4 Removing the Upper Door	4-3
4.1.5 Grate-shaped Upper Guide	4-3
4.1.5.1 Removing the Front Cover	4-3
4.1.5.2 Removing the Rear Cover	4-4
4.1.5.3 Removing the Left Upper Cover	4-4
4.1.5.4 Removing the Grate-shaped Upper Guide	4-4
4.1.6 Grate-shaped Lower Guide	4-5
4.1.6.1 Removing the Front Cover	4-5
4.1.6.2 Removing the Rear Cover	4-5
4.1.6.3 Removing the Left Upper Cover	4-5
4.1.6.4 Removing the Grate-shaped Upper Guide	4-6
4.1.6.5 Removing the Tray 1	4-6
4.1.6.6 Removing the Tray 2.....	4-7
4.1.6.7 Removing the Grate-shaped Lower Guide.....	4-8
4.2 Drive System	4-9
4.2.1 Stapler.....	4-9
4.2.1.1 Removing the Front Cover	4-9
4.2.1.2 Removing the Stapler	4-9
4.2.2 Swing Unit.....	4-10
4.2.2.1 Removing the Front Cover	4-10
4.2.2.2 Removing the Rear Cover	4-10
4.2.2.3 Removing the Left Upper Cover	4-10
4.2.2.4 Removing the Grate-shaped Upper Guide	4-11
4.2.2.5 Removing the Tray 1	4-11
4.2.2.6 Removing the Tray 2	4-13
4.2.2.7 Removing the Grate-shaped Lower Guide.....	4-14
4.2.2.8 Removing the Processing Tray.....	4-14
4.2.2.9 Removing the Swing Unit	4-15
4.3 Document Feeding System.....	4-17
4.3.1 Process Tray Assembly	4-17
4.3.1.1 Removing the Front Cover	4-17

4.3.1.2 Removing the Rear Cover.....	4-17
4.3.1.3 Removing the Left Upper Cover	4-17
4.3.1.4 Removing the Grate-shaped Upper Guide.....	4-18
4.3.1.5 Removing the Tray 1	4-18
4.3.1.6 Removing the Tray 2	4-19
4.3.1.7 Removing the Grate-shaped Lower Guide	4-20
4.3.1.8 Removing the Processing Tray	4-20
4.3.2 Tray 1.....	4-22
4.3.2.1 Removing the Front Cover	4-22
4.3.2.2 Removing the Rear Cover.....	4-22
4.3.2.3 Removing the Left Upper Cover	4-22
4.3.2.4 Removing the Tray 1	4-23
4.3.3 Tray 2.....	4-24
4.3.3.1 Removing the Front Cover	4-24
4.3.3.2 Removing the Rear Cover.....	4-24
4.3.3.3 Removing the Left Upper Cover	4-24
4.3.3.4 Removing the Tray 1	4-25
4.3.3.5 Removing the Tray 2	4-26
4.3.4 Buffer Roller.....	4-27
4.3.4.1 Removing the Front Cover	4-27
4.3.4.2 Removing the Rear Cover.....	4-28
4.3.4.3 Removing the Left Upper Cover	4-28
4.3.4.4 Removing the Upper Door.....	4-28
4.3.4.5 Removing the Buffer Roller	4-29
4.3.5 Return Roller	4-29
4.3.5.1 Removing the Front Cover	4-29
4.3.5.2 Removing the Rear Cover.....	4-29
4.3.5.3 Removing the Left Upper Cover	4-30
4.3.5.4 Removing the Grate-shaped Upper Guide.....	4-30
4.3.5.5 Removing the Tray 1	4-30
4.3.5.6 Removing the Tray 2	4-32
4.3.5.7 Removing the Grate-shaped Lower Guide	4-33
4.3.5.8 Removing the Processing Tray	4-33
4.3.5.9 Removing the Return Roller.....	4-34
4.3.6 Return Roller Unit	4-35
4.3.6.1 Removing the Front Cover	4-35
4.3.6.2 Removing the Rear Cover.....	4-35
4.3.6.3 Removing the Left Upper Cover	4-35
4.3.6.4 Removing the Grate-shaped Upper Guide.....	4-36
4.3.6.5 Removing the Tray 1	4-36
4.3.6.6 Removing the Tray 2	4-38
4.3.6.7 Removing the Grate-shaped Lower Guide	4-39
4.3.6.8 Removing the Stapler.....	4-39
4.3.6.9 Removing the Processing Tray	4-40
4.3.6.10 Removing the Swing Unit.....	4-41
4.3.6.11 Removing the Return Roller Unit.....	4-41
4.4 Electrical System	4-43
4.4.1 Finisher Controller PCB	4-43
4.4.1.1 Finisher Controller PCB	4-43

4.4.1.1.1 Removing the Rear Cover	4-43
4.4.1.1.2 Removing the Finisher Controller PCB	4-43
4.4.2 Static Charge Eliminator 1	4-43
4.4.2.1 Removing the Front Cover	4-43
4.4.2.2 Removing the Rear Cover	4-43
4.4.2.3 Removing the Left Upper Cover	4-44
4.4.2.4 Removing the Grate-shaped Upper Guide	4-44
4.4.2.5 Removing the Tray 1	4-44
4.4.2.6 Removing the Tray 2	4-46
4.4.2.7 Removing the Grate-shaped Lower Guide	4-47
4.4.2.8 Removing the Stapler	4-47
4.4.2.9 Removing the Processing Tray.....	4-48
4.4.2.10 Removing the Swing Unit Static Charge Eliminator	4-49
4.4.3 Static Charge Eliminator 2	4-49
4.4.3.1 Removing the Inlet Static Charge Eliminator	4-49

4.1 External Covers

4.1.1 Front Cover

4.1.1.1 Removing the Front Cover

0004-7895

- 1) Remove screw [1] and remove the foot cover [2].

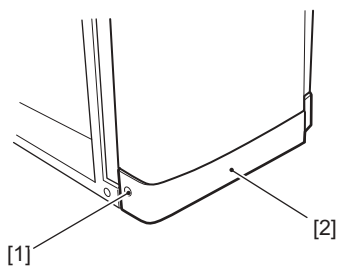

F-4-1

- 2) Open the front door [1] and remove three screws [2].
- 3) Remove the front cover [3].

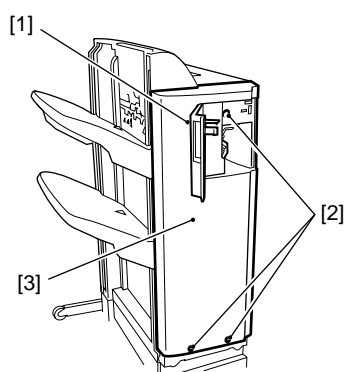

F-4-2

4.1.2 Rear Cover

4.1.2.1 Removing the Rear Cover

0004-4527

- 1) Remove three screws [1] and remove the rear cover [2].

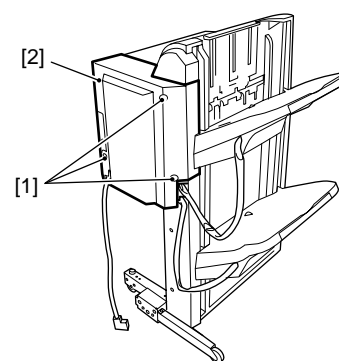

F-4-3

4.1.3 Left Upper Cover

4.1.3.1 Removing the Front Cover

0004-8059

- 1) Remove screw [1] and remove the foot cover [2].

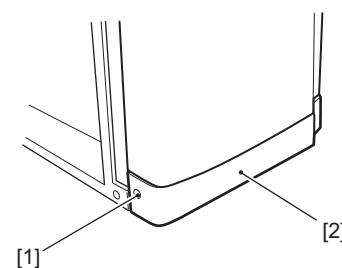

F-4-4

- 2) Open the front door [1] and remove three screws [2].
- 3) Remove the front cover [3].

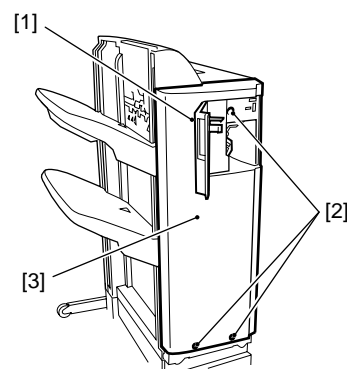

F-4-5

4.1.3.2 Removing the Rear

Cover 0004-4532

- 1) Remove three screws [1] and remove the rear cover [2].

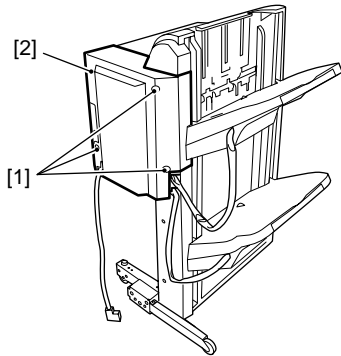

F-4-6

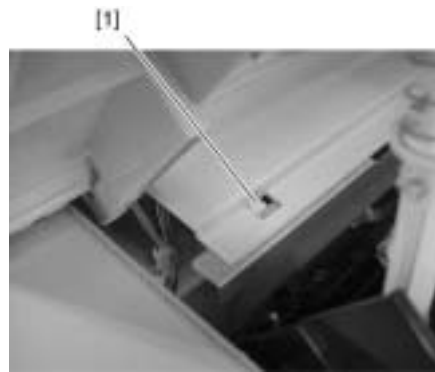

F-4-8

4.1.3.3 Removing the Left

Upper Cover 0004-4534

- 1) Remove two screws [1].
- 2) With the upper door [2] open, remove the left upper cover [3] by tilting to the right.

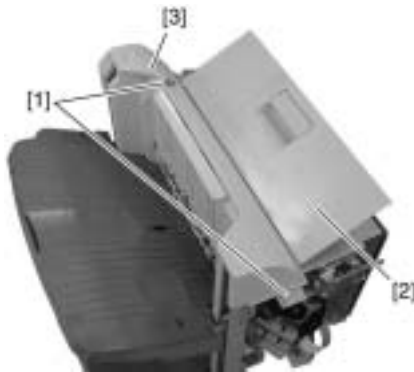

F-4-7

4.1.4 Upper Door

4.1.4.1 Removing the Front

Cover 0004-8061

- 1) Remove screw [1] and remove the foot cover [2].

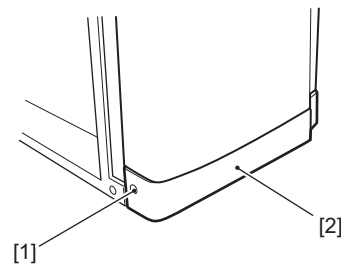

F-4-9

- 2) Open the front door [1] and remove three screws [2].
- 3) Remove the front cover [3].

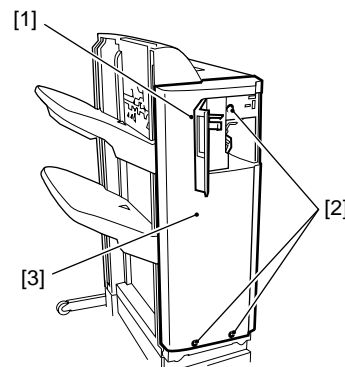

F-4-10

⚠ When replacing, hook the two claws [1] of the left upper cover to the steel plate.

4.1.4.2 Removing the Rear

Cover [0004-4536](#)

- 1) Remove three screws [1] and remove the rear cover [2].

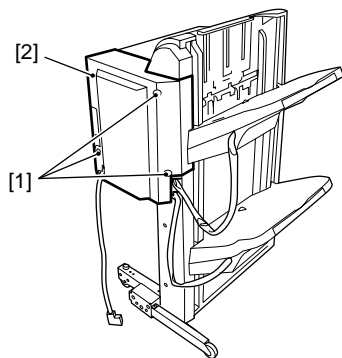

F-4-11

4.1.4.3 Removing the Left

Upper Cover [0004-4538](#)

- 1) Remove two screws [1].
- 2) With the upper door [2] open, remove the left upper cover [3] by tilting to the right.

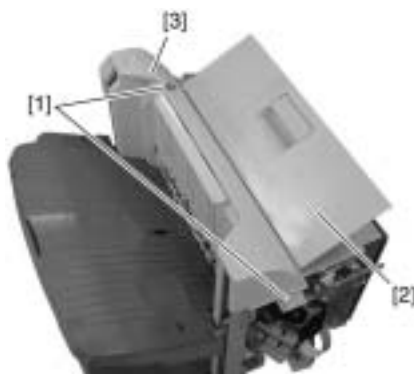

F-4-12

⚠ When replacing, hook the two claws [1] of the left upper cover to the steel plate.

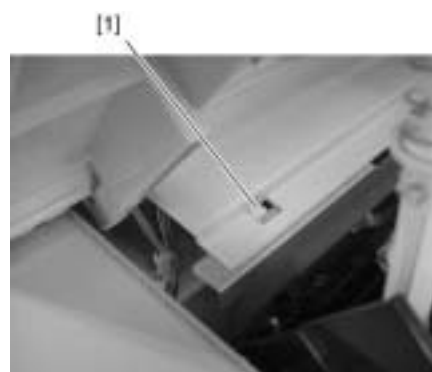

F-4-13

4.1.4.4 Removing the Upper

Door [0004-4539](#)

- 1) Open the upper door [1] and unhook the two hooks [2].
- 2) Remove screw [3] and remove the upper door [1].

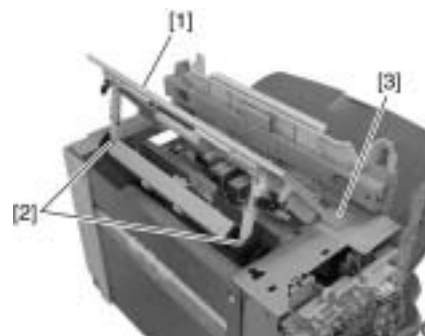

F-4-14

4.1.5 Grate-shaped Upper Guide

4.1.5.1 Removing the Front

Cover [0004-8062](#)

- 1) Remove screw [1] and remove the foot cover [2].

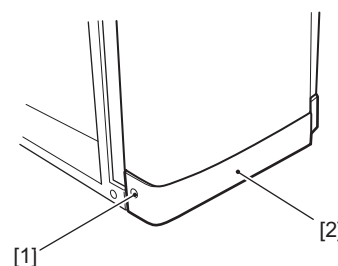

F-4-15

- 2) Open the front door [1] and remove three screws [2].
- 3) Remove the front cover [3].

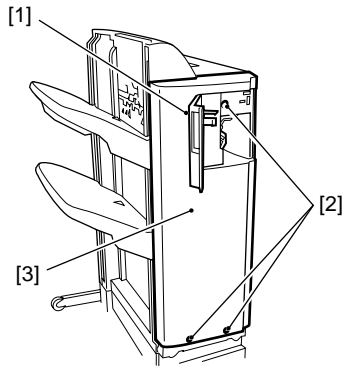

F-4-16

4.1.5.2 Removing the Rear Cover

[0004-4542](#)

- 1) Remove three screws [1] and remove the rear cover [2].

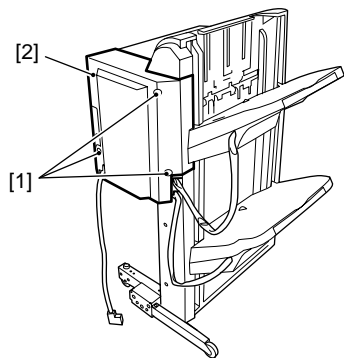

F-4-17

4.1.5.3 Removing the Left Upper Cover

[0004-4543](#)

- 1) Remove two screws [1].
- 2) With the upper door [2] open, remove the left upper cover [3] by tilting to the right.

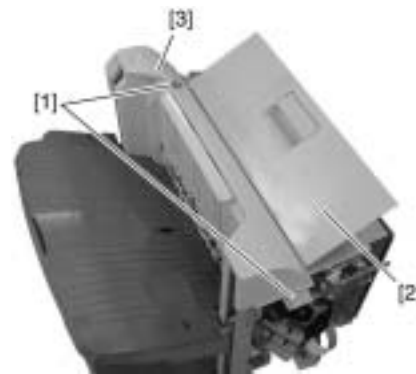

F-4-18

⚠ When replacing, hook the two claws [1] of the left upper cover to the steel plate.

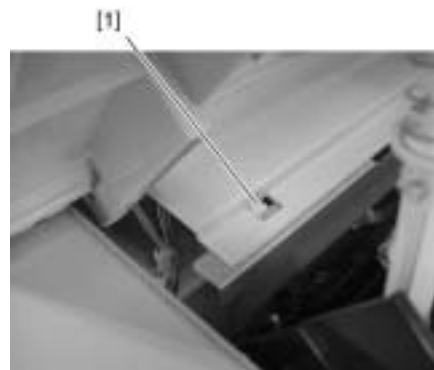

F-4-19

4.1.5.4 Removing the Grate-shaped Upper Guide

[0004-4544](#)

- 1) Lower tray [1] below the grate-shaped upper guide [2] (For how the tray is moved, see the steps under "Removing the Tray 1.").
- 2) Remove five screws [3] and remove the grate-shaped upper guide [2].

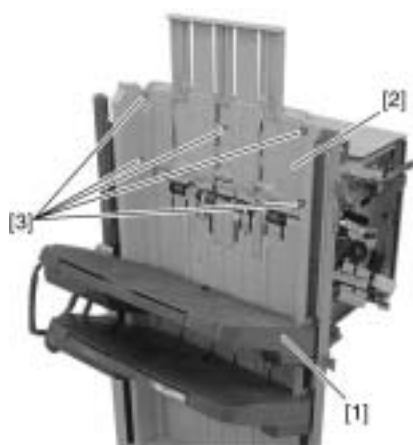

F-4-20

4.1.6 Grate-shaped Lower Guide

4.1.6.1 Removing the Front Cover

0004-8063

- 1) Remove screw [1] and remove the foot cover [2].

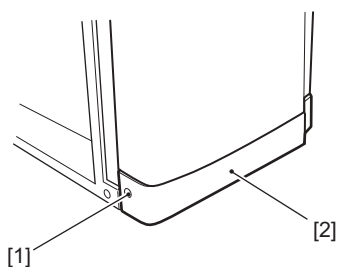

F-4-21

- 2) Open the front door [1] and remove three screws [2].
- 3) Remove the front cover [3].

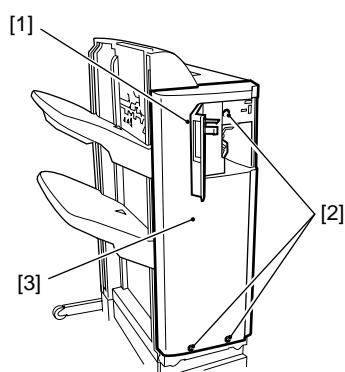

F-4-22

4.1.6.2 Removing the Rear Cover

0004-4547

- 1) Remove three screws [1] and remove the rear cover [2].

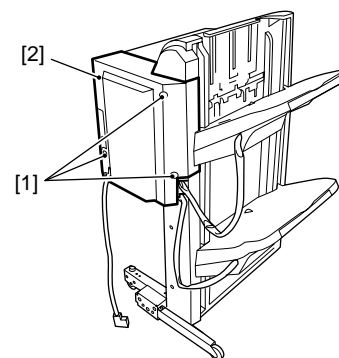

F-4-23

4.1.6.3 Removing the Left Upper Cover

0004-4548

- 1) Remove two screws [1].
- 2) With the upper door [2] open, remove the left upper cover [3] by tilting to the right.



F-4-24

⚠ When replacing, hook the two claws [1] of the left upper cover to the steel plate.

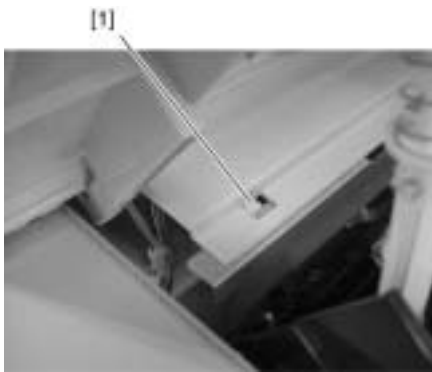

F-4-25

4.1.6.4 Removing the Grate-shaped Upper Guide

0004-4549

- 1) Lower tray [1] below the grate-shaped upper guide [2] (For how the tray is moved, see the steps under "Removing the Tray 1.").
- 2) Remove five screws [3] and remove the grate-shaped upper guide [2].

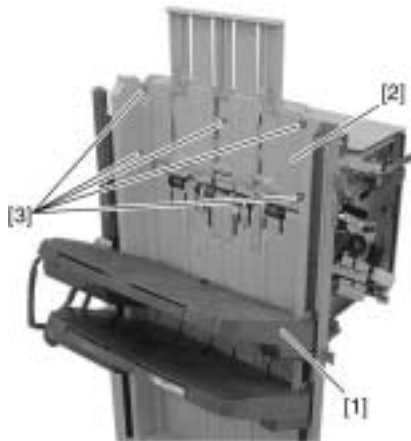

F-4-26

4.1.6.5 Removing the Tray 1

0004-4555

⚠ When you attach or remove the tray, please be sure to raise the shutter [1], release the latch [3] on the rear surface of the tray while the stack delivery gate [2] of the delivery opening is lifted (covered), and then move down the tray. If you move down the tray without lifting the shutter of the delivery opening, the stack delivery gate comes off from the

Finisher. If the stack delivery gate comes off, remount it while paying attention so as not to lose the spring for the shaft of the stack delivery gate. The tray falls by its own weight when the latch is released, so be sure to hold the tray with hands.

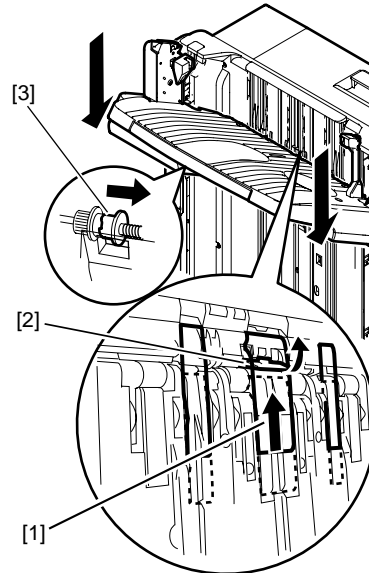

F-4-27

- 1) Remove screw [1] and remove the steel plate [2] and slide guide [3]. However, if the grate-shaped upper guide is removed, this step is not necessary.

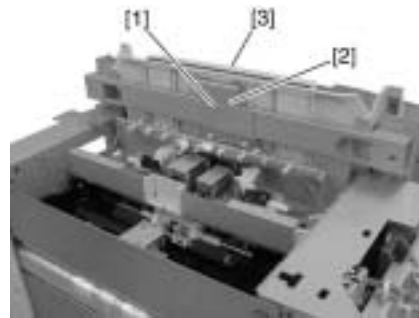

F-4-28

- 2) Remove screw [1] and remove the stopper [2].

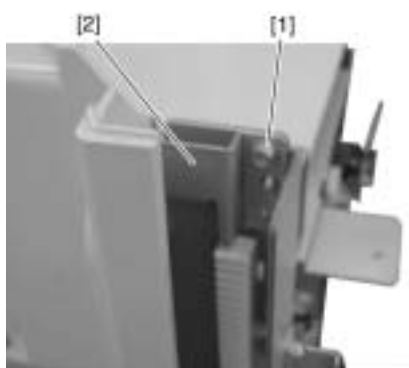

F-4-29

- 3) Remove two screws [1], open two harness retainers [2] and disconnect two connectors [3].

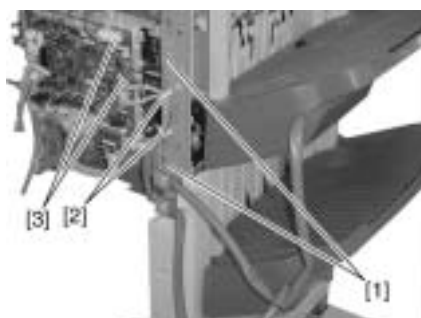

F-4-30

- 4) Insert your finger in the hole at the rear side of tray 1 [1], push the tray lift motor gear [2] to the front to release the clutch and lift tray 1 [1].

⚠ When the tray lift motor gear clutch is released, the tray drops by its own weight. Therefore, hold the tray with your hand when releasing the clutch. Also, be careful not to twist the tray cable when installing.

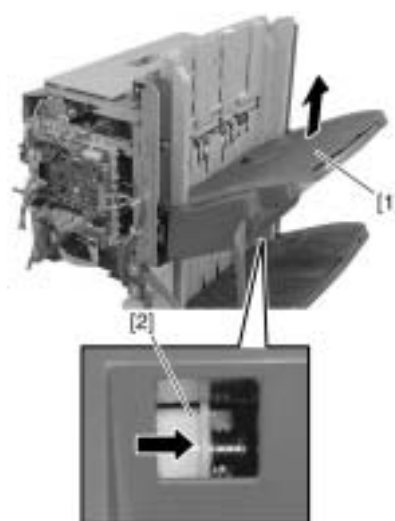

F-4-31

4.1.6.6 Removing the Tray 2 0004-4566

⚠ When you attach or remove the tray, please be sure to raise the shutter [1], release the latch [3] on the rear surface of the tray while the stack delivery gate [2] of the delivery opening is lifted (covered), and then move down the tray. If you move down the tray without lifting the shutter of the delivery opening, the stack delivery gate comes off from the Finisher. If the stack delivery gate comes off, remount it while paying attention so as not to lose the spring for the shaft of the stack delivery gate. The tray falls by its own weight when the latch is released, so be sure to hold the tray with hands.

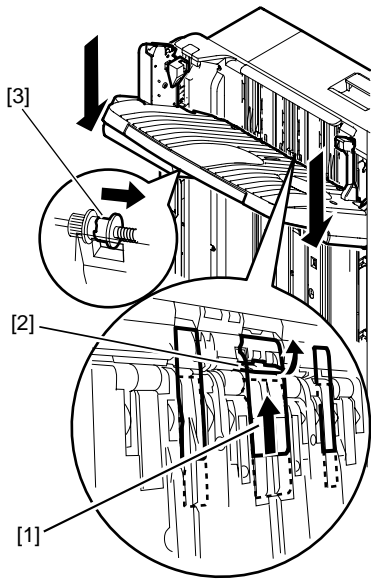

F-4-32

1) Remove screw [1] and remove the stopper [2].

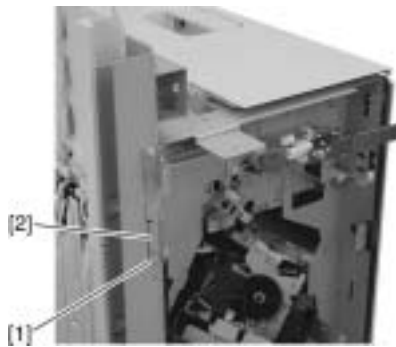

F-4-33

2) Remove two screws [1] and disconnect connector [2].

3) Insert your finger in the hole at the rear side of tray 2 [3], push the tray lift motor gear [4] to the front to release the clutch and lift tray 2 [3].

⚠ When the tray lift motor gear clutch is released the tray drops by its own weight. Therefore, hold the tray with your hand when releasing the clutch. Also, be careful not to twist the tray cable when installing.

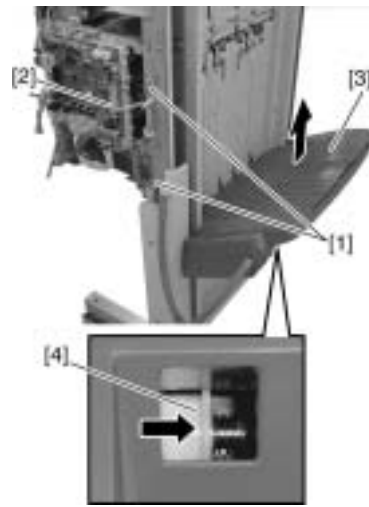

F-4-34

4.1.6.7 Removing the Grate-shaped Lower Guide 0004-4567

1) Remove ten screws [1] and remove the grate-shaped lower guide [2].

⚠ When replacing, be careful not to hook the grate-shaped lower guide to the sensor flag arm on the delivery side.

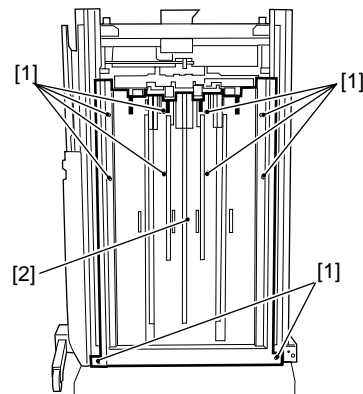

F-4-35

4.2 Drive System

4.2.1 Stapler

4.2.1.1 Removing the Front Cover

0004-8065

- 1) Remove screw [1] and remove the foot cover [2].

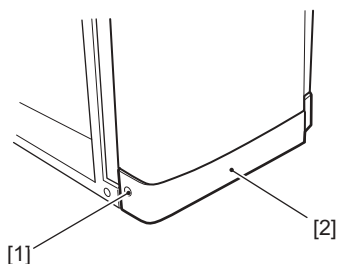

F-4-36

- 2) Open the front door [1] and remove three screws [2].
- 3) Remove the front cover [3].

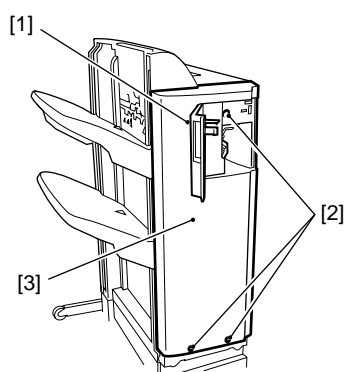

F-4-37

4.2.1.2 Removing the Stapler

0004-4570

- 1) Pull out the stapler, remove screw [1], and remove the PCB cover [2].

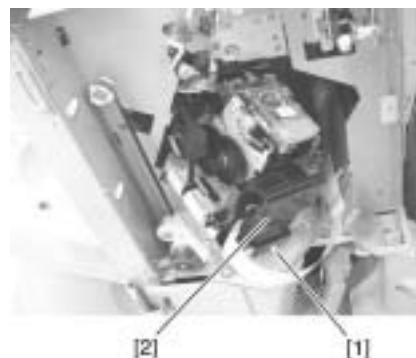

F-4-38

- 2) Release the claw [1] and remove the PCB [2].
- 3) Disconnect three connectors [3].
- 4) Remove screw [4] and remove the stapler together with the stapler base [5].

⚠ When removing, be careful not to damage the flag [6].

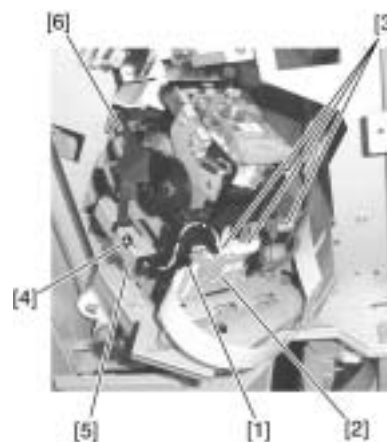

F-4-39

- 5) Turn the stapler over, disconnect two connectors [1], remove two screws [2], and remove the stapler from the stapler base.

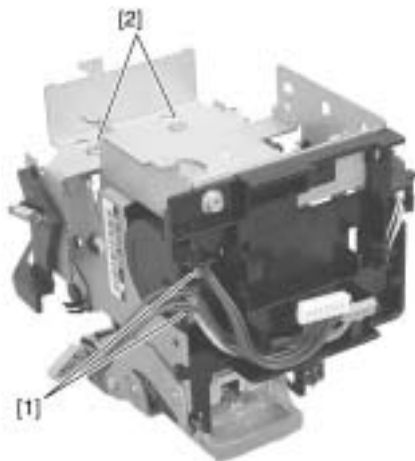

F-4-40

4.2.2 Swing Unit

4.2.2.1 Removing the Front Cover

0004-8067

- 1) Remove screw [1] and remove the foot cover [2].

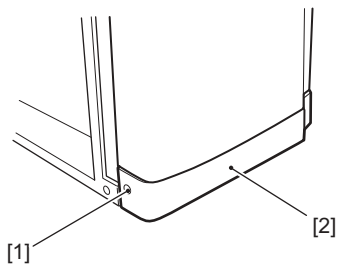

F-4-41

- 2) Open the front door [1] and remove three screws [2].
- 3) Remove the front cover [3].

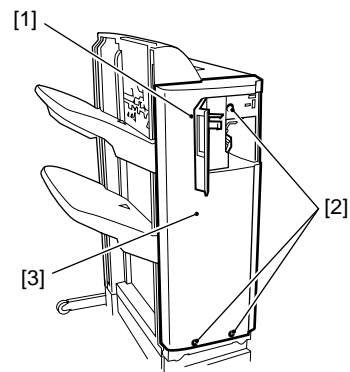

F-4-42

4.2.2.2 Removing the Rear Cover

0004-4572

- 1) Remove three screws [1] and remove the rear cover [2].

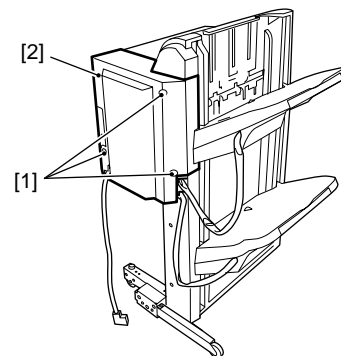

F-4-43

4.2.2.3 Removing the Left Upper Cover

0004-4573

- 1) Remove two screws [1].
- 2) With the upper door [2] open, remove the left upper cover [3] by tilting to the right.

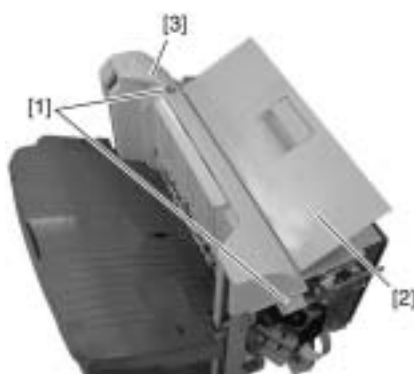

F-4-44

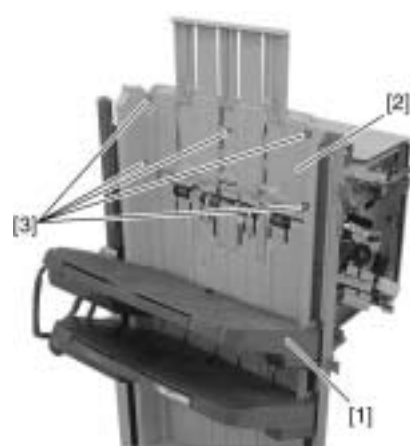

F-4-46

⚠ When replacing, hook the two claws [1] of the left upper cover to the steel plate.

4.2.2.5 Removing the Tray 1 [0004-4575](#)

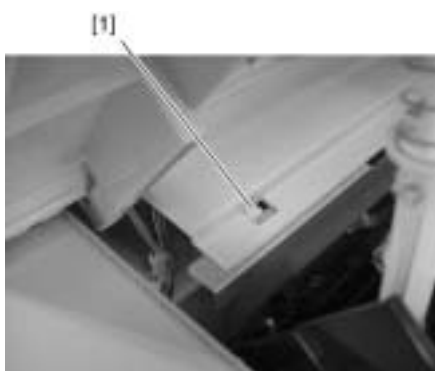

F-4-45

⚠ When you attach or remove the tray, please be sure to raise the shutter [1], release the latch [3] on the rear surface of the tray while the stack delivery gate [2] of the delivery opening is lifted (covered), and then move down the tray. If you move down the tray without lifting the shutter of the delivery opening, the stack delivery gate comes off from the Finisher. If the stack delivery gate comes off, remount it while paying attention so as not to lose the spring for the shaft of the stack delivery gate. The tray falls by its own weight when the latch is released, so be sure to hold the tray with hands.

4.2.2.4 Removing the Grate-shaped Upper Guide [0004-4574](#)

- 1) Lower tray [1] below the grate-shaped upper guide [2] (For how the tray is moved, see the steps under "Removing the Tray 1.>").
- 2) Remove five screws [3] and remove the grate-shaped upper guide [2].

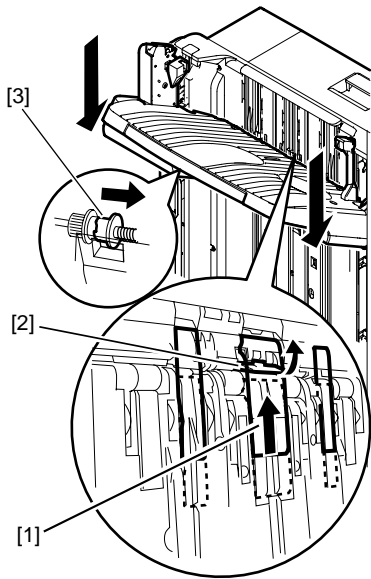

F-4-47

1) Remove screw [1] and remove the steel plate [2] and slide guide [3]. However, if the grate-shaped upper guide is removed, this step is not necessary.

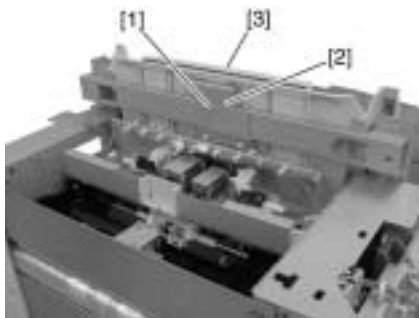

F-4-48

2) Remove screw [1] and remove the stopper [2].

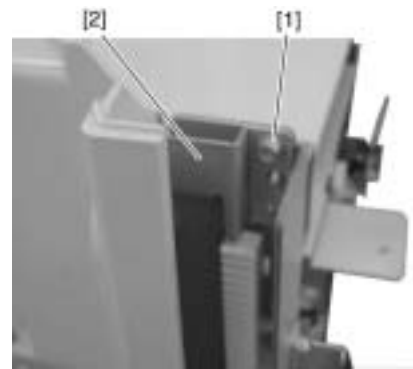

F-4-49

3) Remove two screws [1], open two harness retainers [2] and disconnect two connectors [3].

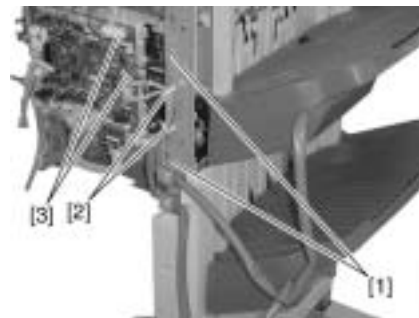

F-4-50

4) Insert your finger in the hole at the rear side of tray 1 [1], push the tray lift motor gear [2] to the front to release the clutch and lift tray 1 [1].

⚠ When the tray lift motor gear clutch is released, the tray drops by its own weight. Therefore, hold the tray with your hand when releasing the clutch. Also, be careful not to twist the tray cable when installing.

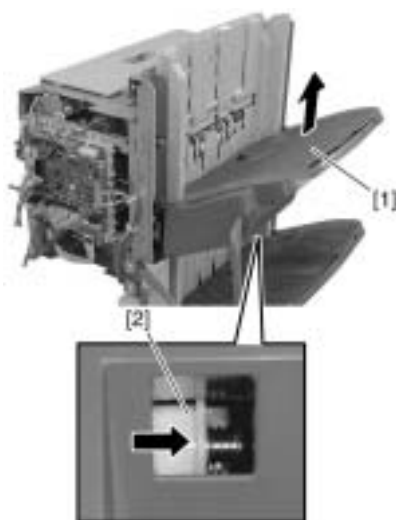

F-4-51

4.2.2.6 Removing the Tray 2

0004-4576

⚠ When you attach or remove the tray, please be sure to raise the shutter [1], release the latch [3] on the rear surface of the tray while the stack delivery gate [2] of the delivery opening is lifted (covered), and then move down the tray. If you move down the tray without lifting the shutter of the delivery opening, the stack delivery gate comes off from the Finisher. If the stack delivery gate comes off, remount it while paying attention so as not to lose the spring for the shaft of the stack delivery gate. The tray falls by its own weight when the latch is released, so be sure to hold the tray with hands.

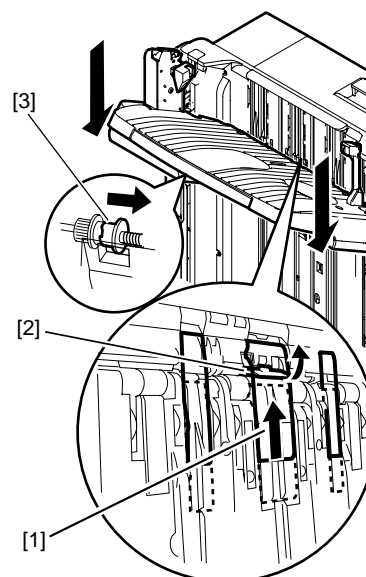

F-4-52

1) Remove screw [1] and remove the stopper [2].

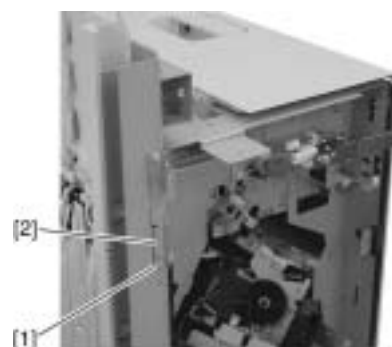

F-4-53

2) Remove two screws [1] and disconnect connector [2].

3) Insert your finger in the hole at the rear side of tray 2 [3], push the tray lift motor gear [4] to the front to release the clutch and lift tray 2 [3].

⚠ When the tray lift motor gear clutch is released the tray drops by its own weight. Therefore, hold the tray with your hand when releasing the clutch. Also, be careful not to twist the tray cable when installing.

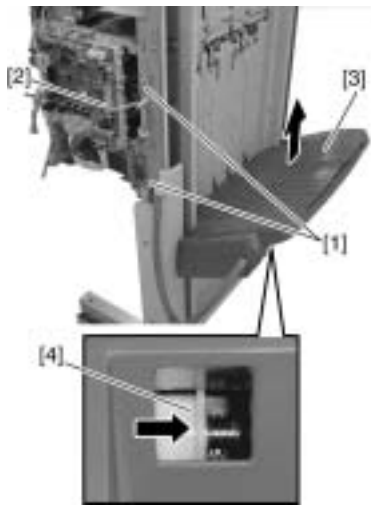

F-4-54

4.2.2.7 Removing the Grate-shaped Lower Guide

0004-4577

1) Remove ten screws [1] and remove the grate-shaped lower guide [2].

⚠When replacing, be careful not to hook the grate-shaped lower guide to the sensor flag arm on the delivery side.

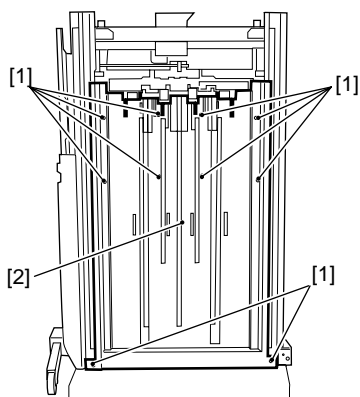

F-4-55

4.2.2.8 Removing the Processing Tray

0004-4587

1) Unfasten four snap fasteners [1] and remove the sensor flag [3] from the stack delivery roller [2].

⚠Hold the snap fastener at the base when unfastening because the sensor flag arm can break easily. When fastening, insert the boss of the sensor flag snap fastener in the hole on the processing tray side.

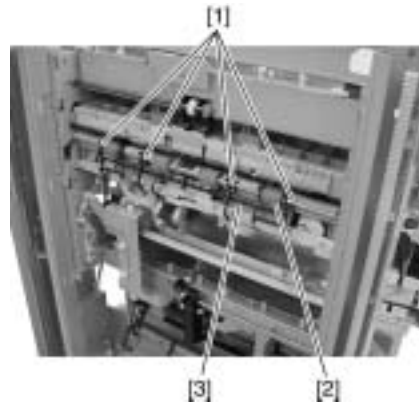

F-4-56

2) Remove the stack delivery roller front side E ring [1], gear [2], parallel pin [3], E ring [4], and bushing [5].

⚠The parallel pin [3] drops when the gear [2] is removed. Be careful not to loose it.

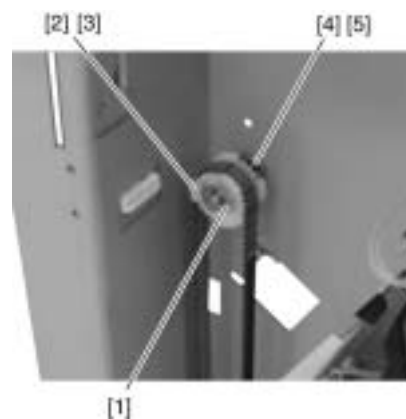

F-4-57

3) Remove all finisher controller PCB connectors[1].
4) Remove four screws [2]. Remove the screw [3]

securing the ground wire and remove the finisher controller PCB [4].

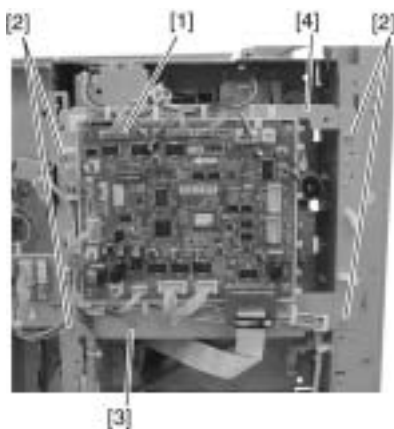

F-4-58

5) Release the claw [2] of the stack delivery roller rear side clutch [1] and remove the clutch [1].

6) Remove the E ring [3] and bushing [4] and remove the stack delivery roller.

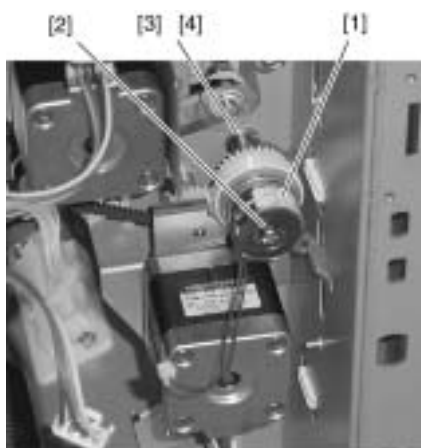

F-4-59

7) Disconnect the connector [1] and remove harness from the clamp and edge saddle [2].

8) Remove two screws [3] and pull out the processing tray [4] in the paper delivery direction.

⚠ When removing parts inside the processing tray, be careful not to exert force on the aligning plate (front/rear) or the rear end stopper plate.

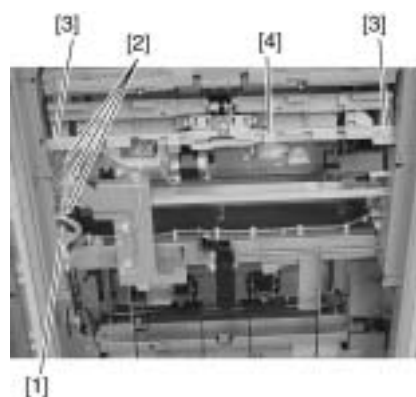

F-4-60

4.2.2.9 Removing the Swing Unit

0004-4588

1) Remove screw [1] and pull up the swing pressure guide [2].

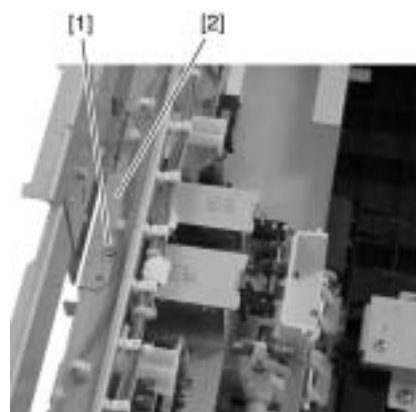

F-4-61

2) Remove two E rings [1] at the joint between the swing unit and the return roller unit and then slide the two return roller unit collars [2] inside.

3) Unhook the swing pressure rack [3] from the swing unit center hook.

4) Remove the belt on the gear [4] at the rear side of the swing unit and then pull out the swing unit [5] from the delivery direction.

⚠ The parallel pin [6] drops when the gear [4] is removed. Be careful not to lose it.

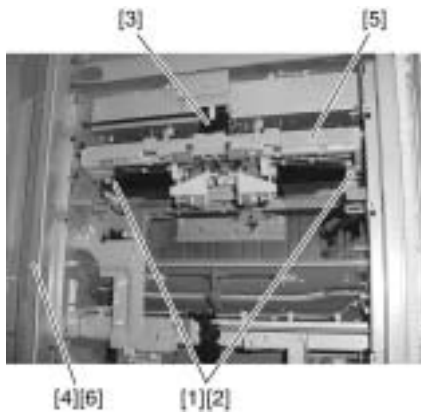

F-4-62

4.3 Document Feeding System

4.3.1 Process Tray Assembly

4.3.1.1 Removing the Front Cover

0004-8069

- 1) Remove screw [1] and remove the foot cover [2].

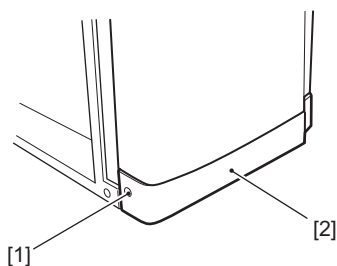

F-4-63

- 2) Open the front door [1] and remove three screws [2].
- 3) Remove the front cover [3].

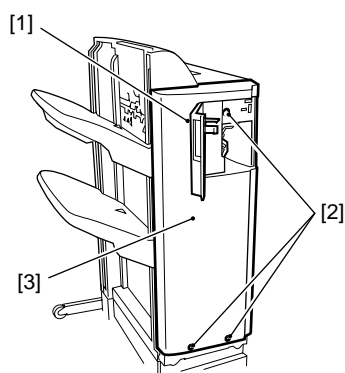

F-4-64

4.3.1.2 Removing the Rear Cover

0004-4579

- 1) Remove three screws [1] and remove the rear cover [2].

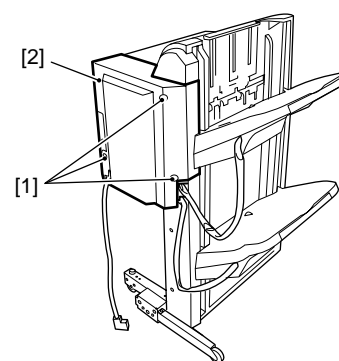

F-4-65

4.3.1.3 Removing the Left Upper Cover

0004-4580

- 1) Remove two screws [1].
- 2) With the upper door [2] open, remove the left upper cover [3] by tilting to the right.

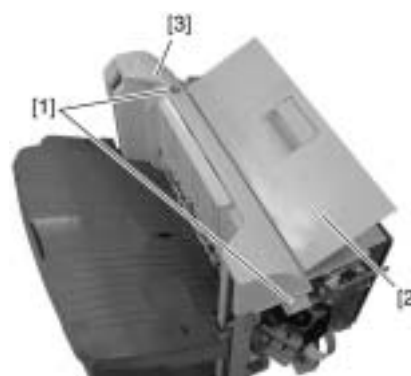

F-4-66

⚠ When replacing, hook the two claws [1] of the left upper cover to the steel plate.

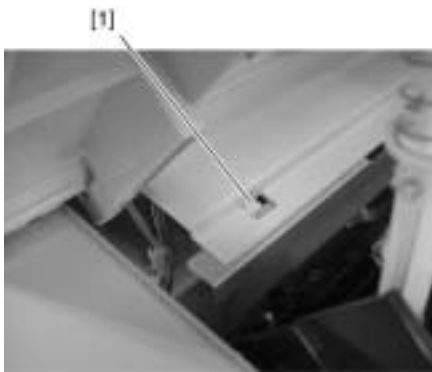

F-4-67

4.3.1.4 Removing the Grate-shaped Upper Guide

0004-4581

- 1) Lower tray [1] below the grate-shaped upper guide [2] (For how the tray is moved, see the steps under "Removing the Tray 1.>").
- 2) Remove five screws [3] and remove the grate-shaped upper guide [2].

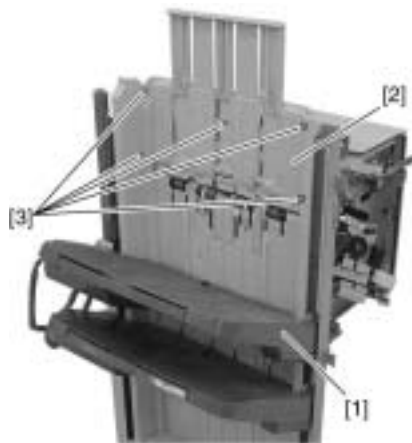

F-4-68

4.3.1.5 Removing the Tray 1

0004-4582

⚠ When you attach or remove the tray, please be sure to raise the shutter [1], release the latch [3] on the rear surface of the tray while the stack delivery gate [2] of the delivery opening is lifted (covered), and then move down the tray. If you move down the tray without lifting the shutter of the delivery opening, the stack delivery gate comes off from the

Finisher. If the stack delivery gate comes off, remount it while paying attention so as not to lose the spring for the shaft of the stack delivery gate. The tray falls by its own weight when the latch is released, so be sure to hold the tray with hands.

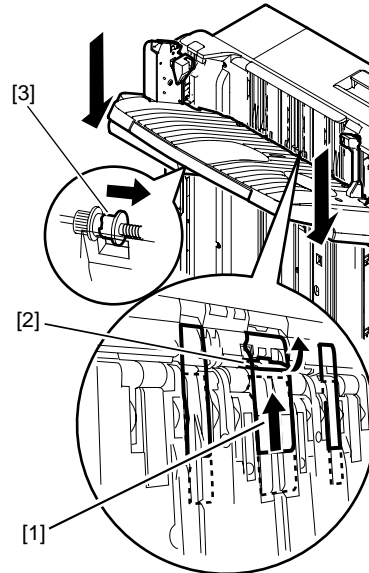

F-4-69

- 1) Remove screw [1] and remove the steel plate [2] and slide guide [3]. However, if the grate-shaped upper guide is removed, this step is not necessary.

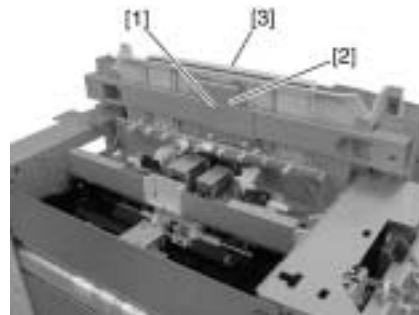

F-4-70

- 2) Remove screw [1] and remove the stopper [2].

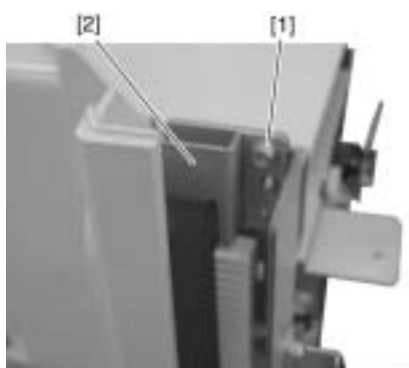

F-4-71

- 3) Remove two screws [1], open two harness retainers [2] and disconnect two connectors [3].

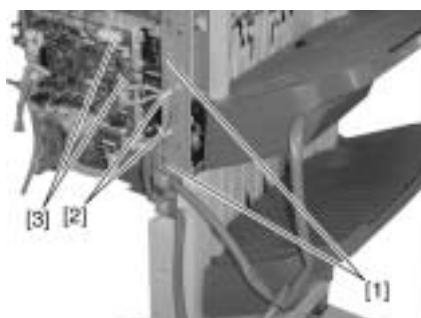

F-4-72

- 4) Insert your finger in the hole at the rear side of tray 1 [1], push the tray lift motor gear [2] to the front to release the clutch and lift tray 1 [1].

⚠ When the tray lift motor gear clutch is released, the tray drops by its own weight. Therefore, hold the tray with your hand when releasing the clutch. Also, be careful not to twist the tray cable when installing.

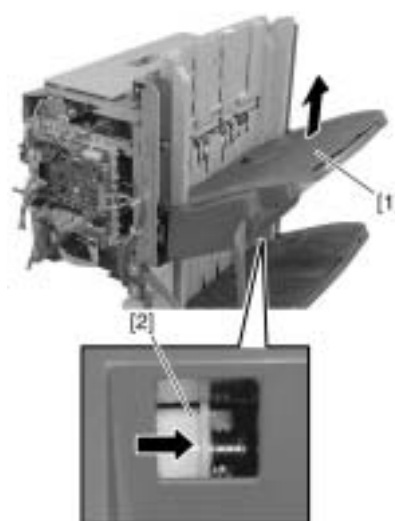

F-4-73

4.3.1.6 Removing the Tray 2 0004-4583

⚠ When you attach or remove the tray, please be sure to raise the shutter [1], release the latch [3] on the rear surface of the tray while the stack delivery gate [2] of the delivery opening is lifted (covered), and then move down the tray. If you move down the tray without lifting the shutter of the delivery opening, the stack delivery gate comes off from the Finisher. If the stack delivery gate comes off, remount it while paying attention so as not to lose the spring for the shaft of the stack delivery gate. The tray falls by its own weight when the latch is released, so be sure to hold the tray with hands.

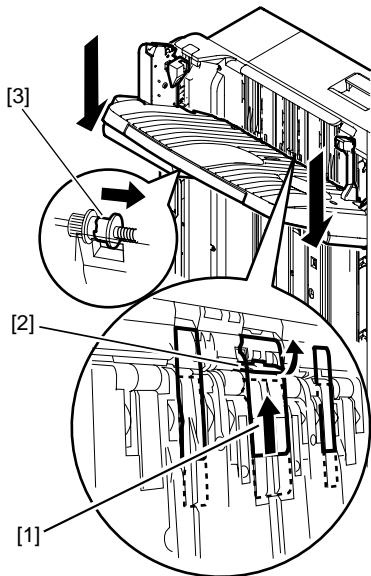

F-4-74

1) Remove screw [1] and remove the stopper [2].

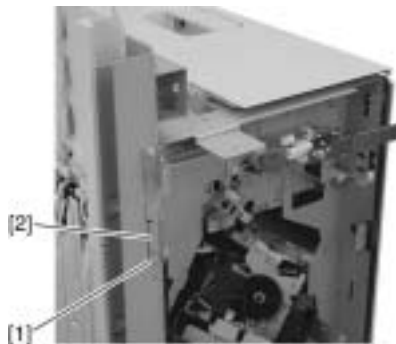

F-4-75

2) Remove two screws [1] and disconnect connector [2].

3) Insert your finger in the hole at the rear side of tray 2 [3], push the tray lift motor gear [4] to the front to release the clutch and lift tray 2 [3].

⚠ When the tray lift motor gear clutch is released the tray drops by its own weight. Therefore, hold the tray with your hand when releasing the clutch. Also, be careful not to twist the tray cable when installing.

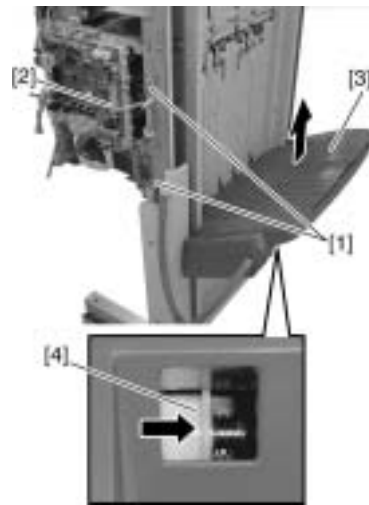

F-4-76

4.3.1.7 Removing the Grate-shaped Lower Guide 0004-4584

1) Remove ten screws [1] and remove the grate-shaped lower guide [2].

⚠ When replacing, be careful not to hook the grate-shaped lower guide to the sensor flag arm on the delivery side.

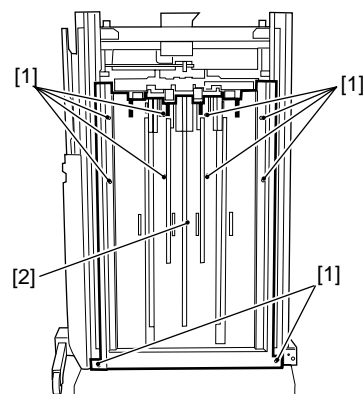

F-4-77

4.3.1.8 Removing the Processing Tray 0004-4586

1) Unfasten four snap fasteners [1] and remove the sensor flag [3] from the stack delivery roller [2].

⚠ Hold the snap fastener at the base when unfastening because the sensor flag arm can break easily. When fastening, insert the boss of the sensor flag snap fastener in the hole on the processing tray side.

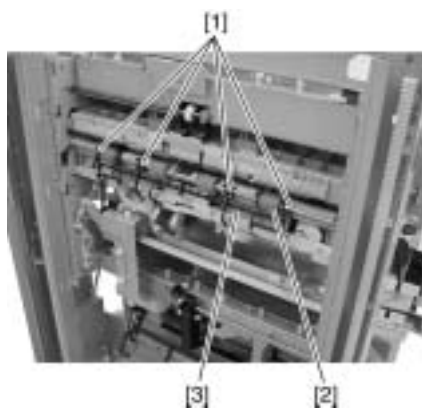

F-4-78

2) Remove the stack delivery roller front side E ring [1], gear [2], parallel pin [3], E ring [4], and bushing [5].

⚠ The parallel pin [3] drops when the gear [2] is removed. Be careful not to lose it.

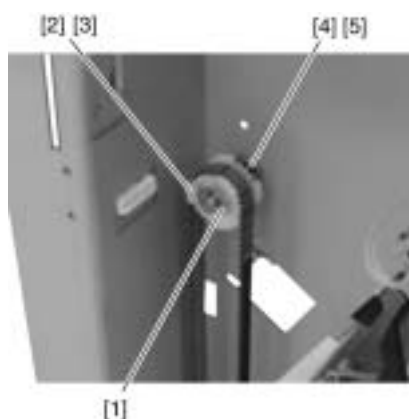

F-4-79

3) Remove all finisher controller PCB connectors [1].
4) Remove four screws [2]. Remove the screw [3]

securing the ground wire and remove the finisher controller PCB [4].

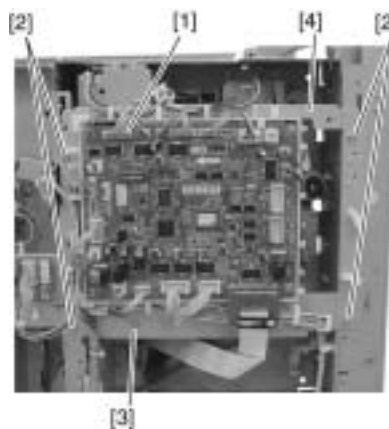

F-4-80

5) Release the claw [2] of the stack delivery roller rear side clutch [1] and remove the clutch [1].

6) Remove the E ring [3] and bushing [4] and remove the stack delivery roller.

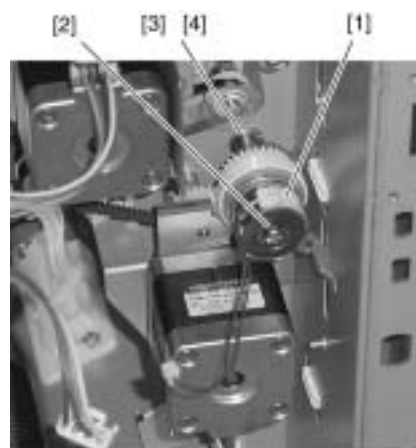

F-4-81

7) Disconnect the connector [1] and remove harness from the clamp and edge saddle [2].

8) Remove two screws [3] and pull out the processing tray [4] in the paper delivery direction.

⚠ When removing parts inside the processing tray, be careful not to exert force on the aligning plate (front/rear) or the rear end stopper plate.

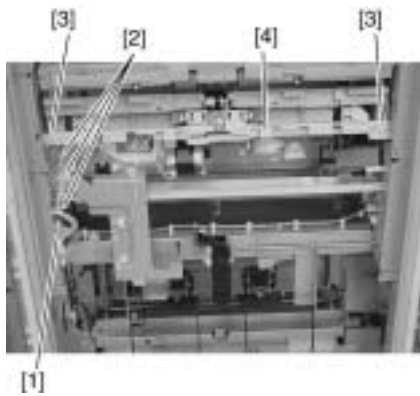

F-4-82

4.3.2.2 Removing the Rear Cover

0004-4551

- 1) Remove three screws [1] and remove the rear cover [2].

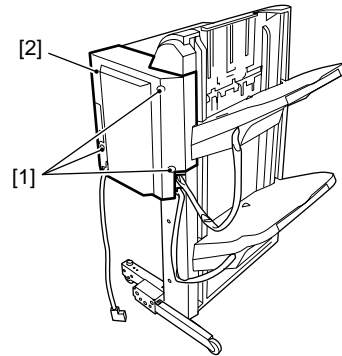

F-4-85

4.3.2 Tray 1

4.3.2.1 Removing the Front Cover

0004-8072

- 1) Remove screw [1] and remove the foot cover [2].

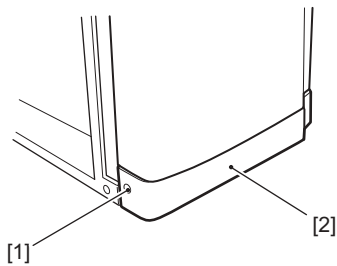

F-4-83

- 2) Open the front door [1] and remove three screws [2].
- 3) Remove the front cover [3].

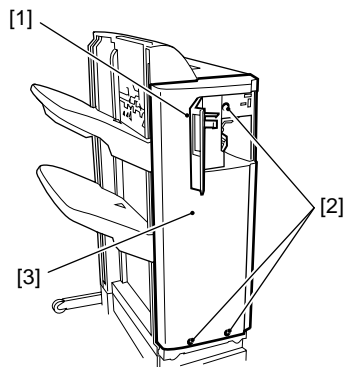

F-4-84

4.3.2.3 Removing the Left Upper Cover

0004-4552

- 1) Remove two screws [1].
- 2) With the upper door [2] open, remove the left upper cover [3] by tilting to the right.

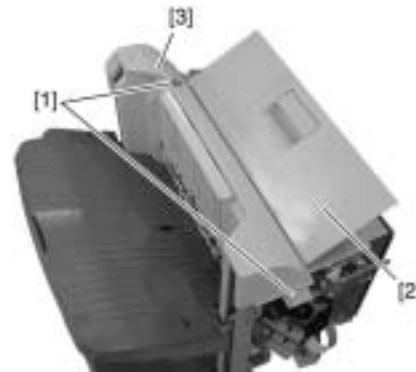

F-4-86

⚠ When replacing, hook the two claws [1] of the left upper cover to the steel plate.

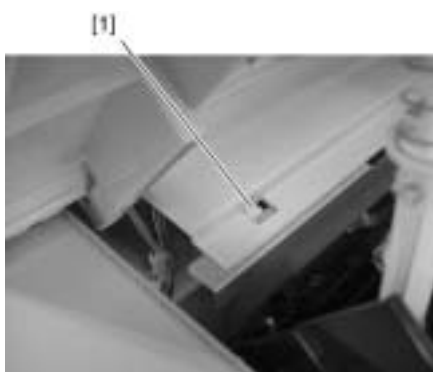

F-4-87

4.3.2.4 Removing the Tray 1 0004-4554

⚠ When you attach or remove the tray, please be sure to raise the shutter [1], release the latch [3] on the rear surface of the tray while the stack delivery gate [2] of the delivery opening is lifted (covered), and then move down the tray. If you move down the tray without lifting the shutter of the delivery opening, the stack delivery gate comes off from the Finisher. If the stack delivery gate comes off, remount it while paying attention so as not to lose the spring for the shaft of the stack delivery gate. The tray falls by its own weight when the latch is released, so be sure to hold the tray with hands.

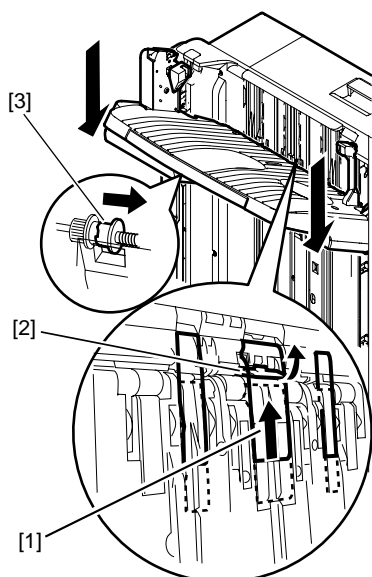

F-4-88

1) Remove screw [1] and remove the steel plate [2] and slide guide [3]. However, if the grate-shaped upper guide is removed, this step is not necessary.

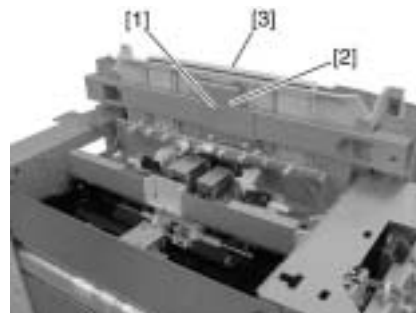

F-4-89

2) Remove screw [1] and remove the stopper [2].

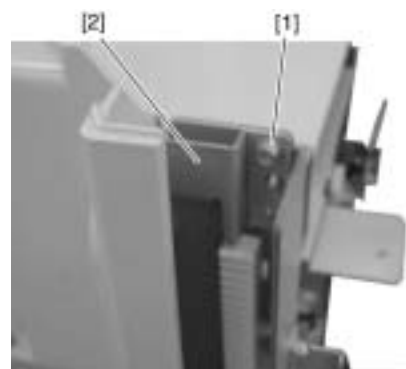

F-4-90

3) Remove two screws [1], open two harness retainers [2] and disconnect two connectors [3].

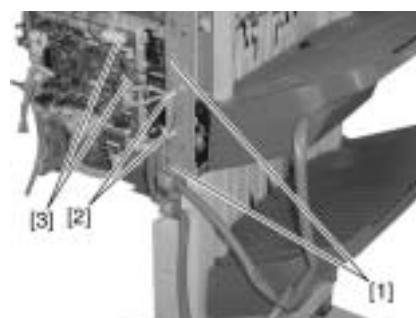

F-4-91

4) Insert your finger in the hole at the rear side of tray 1 [1], push the tray lift motor gear [2] to the front to

release the clutch and lift tray 1 [1].

⚠ When the tray lift motor gear clutch is released, the tray drops by its own weight. Therefore, hold the tray with your hand when releasing the clutch. Also, be careful not to twist the tray cable when installing.

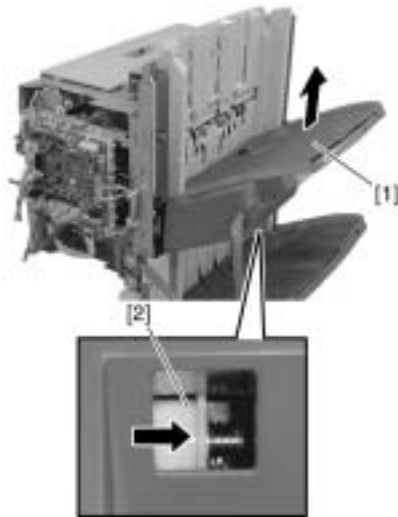

F-4-92

4.3.3 Tray 2

4.3.3.1 Removing the Front Cover

0004-8073

1) Remove screw [1] and remove the foot cover [2].

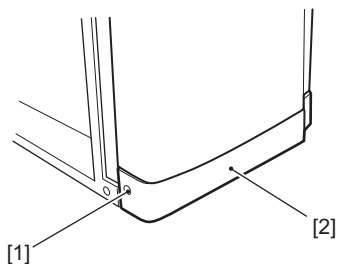

F-4-93

- 2) Open the front door [1] and remove three screws [2].
- 3) Remove the front cover [3].

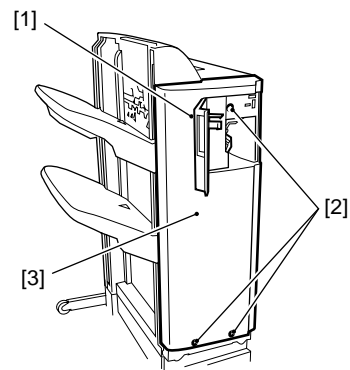

F-4-94

4.3.3.2 Removing the Rear Cover

0004-4558

1) Remove three screws [1] and remove the rear cover [2].

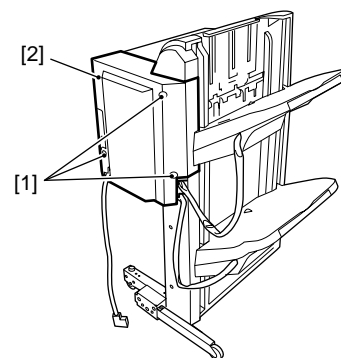

F-4-95

4.3.3.3 Removing the Left Upper Cover

0004-4559

- 1) Remove two screws [1].
- 2) With the upper door [2] open, remove the left upper cover [3] by tilting to the right.

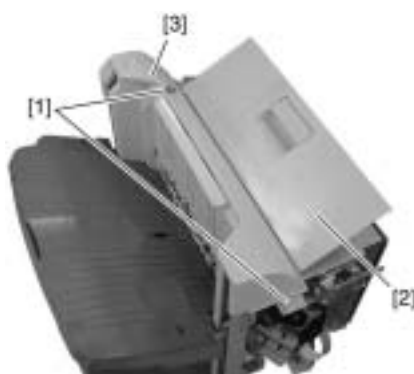

F-4-96

⚠ When replacing, hook the two claws [1] of the left upper cover to the steel plate.

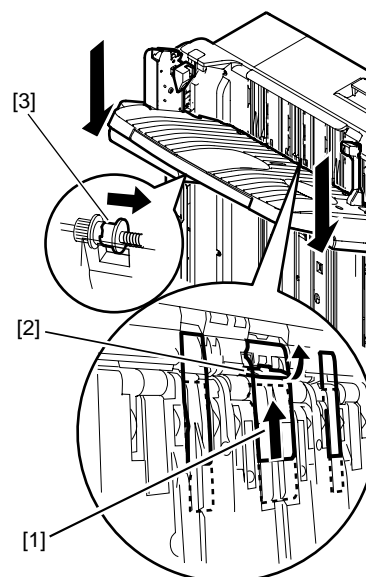

F-4-98

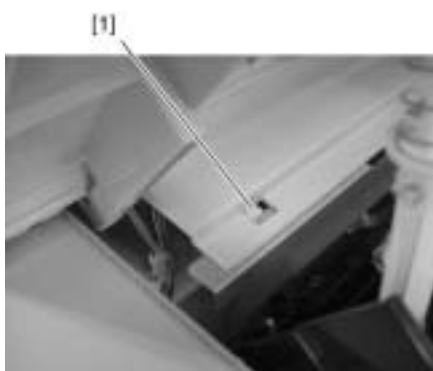

F-4-97

4.3.3.4 Removing the Tray 1 [0004-4564](#)

⚠ When you attach or remove the tray, please be sure to raise the shutter [1], release the latch [3] on the rear surface of the tray while the stack delivery gate [2] of the delivery opening is lifted (covered), and then move down the tray. If you move down the tray without lifting the shutter of the delivery opening, the stack delivery gate comes off from the Finisher. If the stack delivery gate comes off, remount it while paying attention so as not to lose the spring for the shaft of the stack delivery gate. The tray falls by its own weight when the latch is released, so be sure to hold the tray with hands.

1) Remove screw [1] and remove the steel plate [2] and slide guide [3]. However, if the grate-shaped upper guide is removed, this step is not necessary.

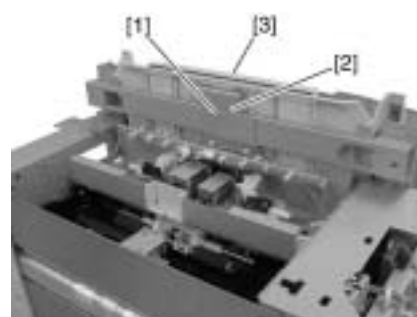

F-4-99

2) Remove screw [1] and remove the stopper [2].

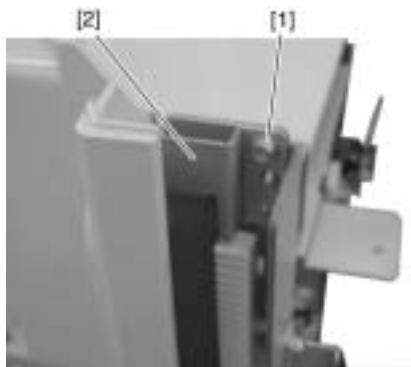

F-4-100

- 3) Remove two screws [1], open two harness retainers [2] and disconnect two connectors [3].

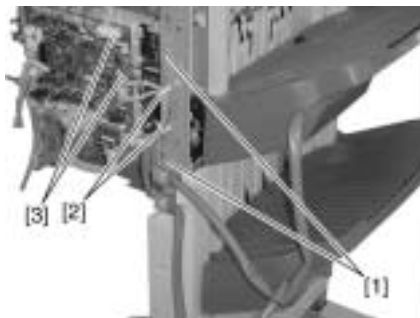

F-4-101

- 4) Insert your finger in the hole at the rear side of tray 1 [1], push the tray lift motor gear [2] to the front to release the clutch and lift tray 1 [1].

⚠ When the tray lift motor gear clutch is released, the tray drops by its own weight. Therefore, hold the tray with your hand when releasing the clutch. Also, be careful not to twist the tray cable when installing.

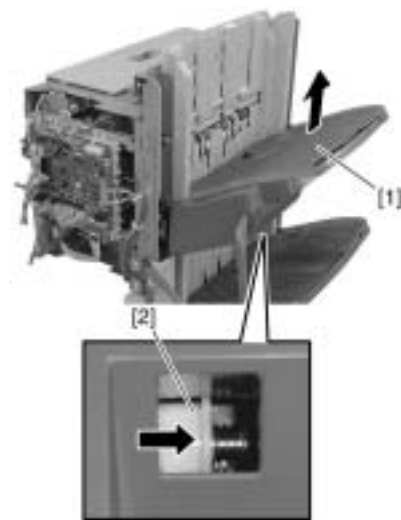

F-4-102

4.3.3.5 Removing the Tray 2 0004-4565

⚠ When you attach or remove the tray, please be sure to raise the shutter [1], release the latch [3] on the rear surface of the tray while the stack delivery gate [2] of the delivery opening is lifted (covered), and then move down the tray. If you move down the tray without lifting the shutter of the delivery opening, the stack delivery gate comes off from the Finisher. If the stack delivery gate comes off, remount it while paying attention so as not to lose the spring for the shaft of the stack delivery gate. The tray falls by its own weight when the latch is released, so be sure to hold the tray with hands.

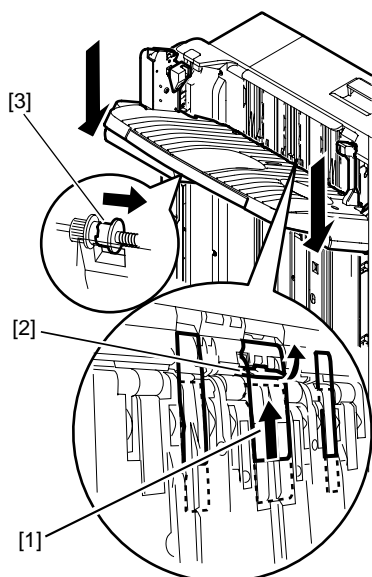

F-4-103

- 1) Remove screw [1] and remove the stopper [2].



F-4-104

- 2) Remove two screws [1] and disconnect connector [2].
 3) Insert your finger in the hole at the rear side of tray 2 [3], push the tray lift motor gear [4] to the front to release the clutch and lift tray 2 [3].

⚠ When the tray lift motor gear clutch is released the tray drops by its own weight. Therefore, hold the tray with your hand when releasing the clutch. Also, be careful not to twist the tray cable when installing.

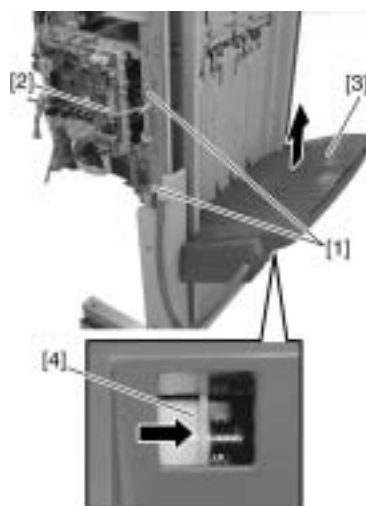

F-4-105

4.3.4 Buffer Roller

4.3.4.1 Removing the Front Cover

0004-8075

- 1) Remove screw [1] and remove the foot cover [2].

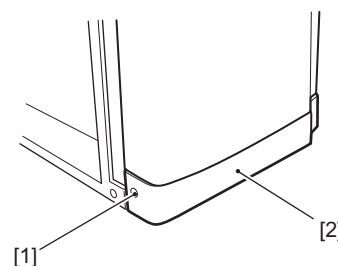

F-4-106

- 2) Open the front door [1] and remove three screws [2].
 3) Remove the front cover [3].

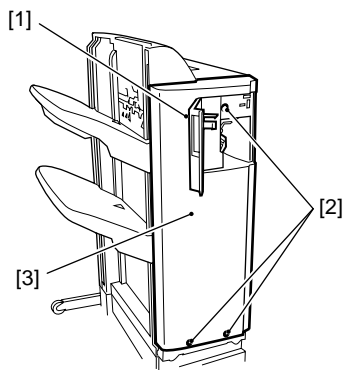

F-4-107

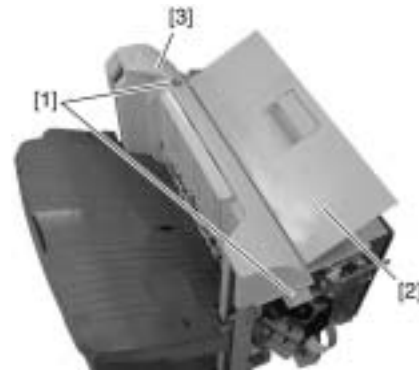

F-4-109

4.3.4.2 Removing the Rear Cover

Cover

0004-4617

- 1) Remove three screws [1] and remove the rear cover [2].

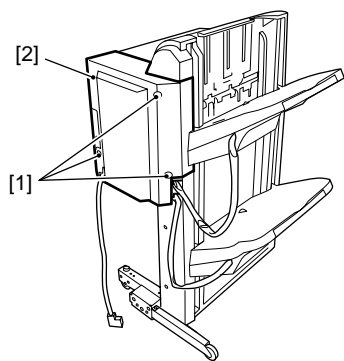

F-4-108

⚠ When replacing, hook the two claws [1] of the left upper cover to the steel plate.

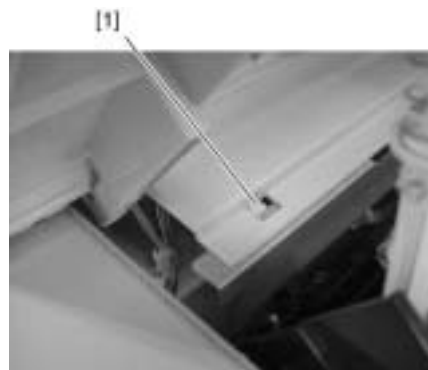

F-4-110

4.3.4.3 Removing the Left Upper Cover

Cover

0004-4619

- 1) Remove two screws [1].
- 2) With the upper door [2] open, remove the left upper cover [3] by tilting to the right.

4.3.4.4 Removing the Upper Door

Door

0004-4620

- 1) Open the upper door [1] and unhook the two hooks [2].
- 2) Remove screw [3] and remove the upper door [1].

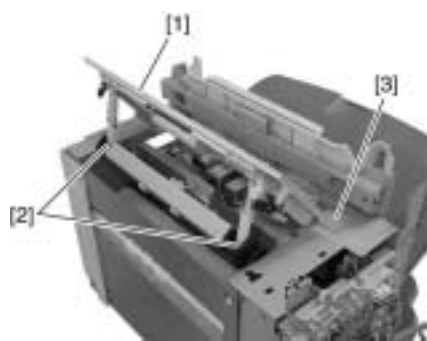

F-4-111

4.3.4.5 Removing the Buffer

Roller

0004-4621

- 1) Remove the buffer roller axis [2] from two arms [1].
- 2) Remove two clips [3] and remove two buffer rollers [4].

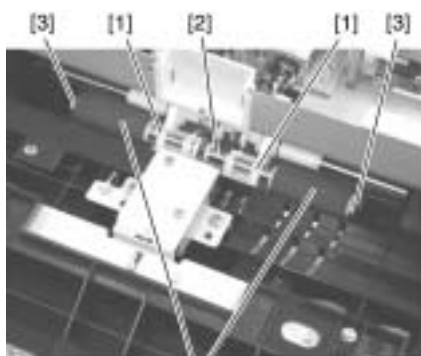

F-4-112

4.3.5 Return Roller

4.3.5.1 Removing the Front

Cover

0004-8076

- 1) Remove screw [1] and remove the foot cover [2].

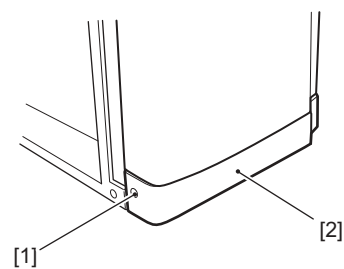

F-4-113

- 2) Open the front door [1] and remove three screws [2].
- 3) Remove the front cover [3].

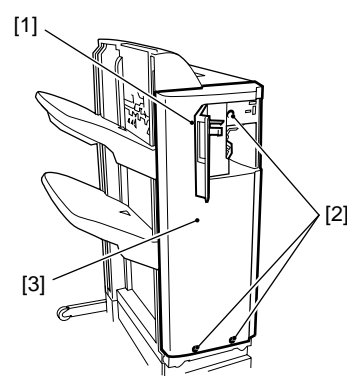

F-4-114

4.3.5.2 Removing the Rear

Cover

0004-4629

- 1) Remove three screws [1] and remove the rear cover [2].

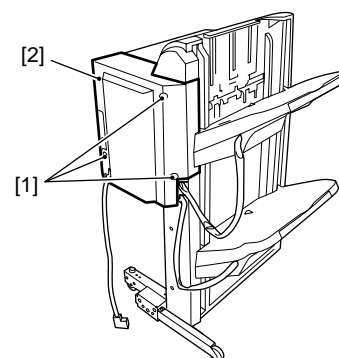

F-4-115

4.3.5.3 Removing the Left

Upper Cover

0004-4632

- 1) Remove two screws [1].
- 2) With the upper door [2] open, remove the left upper cover [3] by tilting to the right.



F-4-116

-
- ⚠** When replacing, hook the two claws [1] of the left upper cover to the steel plate.
-

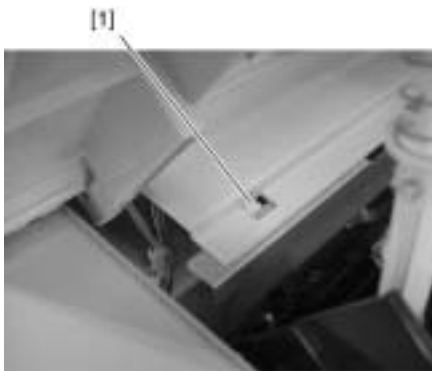

F-4-117

4.3.5.4 Removing the Grate-

shaped Upper Guide

0004-4633

- 1) Lower tray [1] below the grate-shaped upper guide [2] (For how the tray is moved, see the steps under "Removing the Tray 1.").
- 2) Remove five screws [3] and remove the grate-shaped upper guide [2].

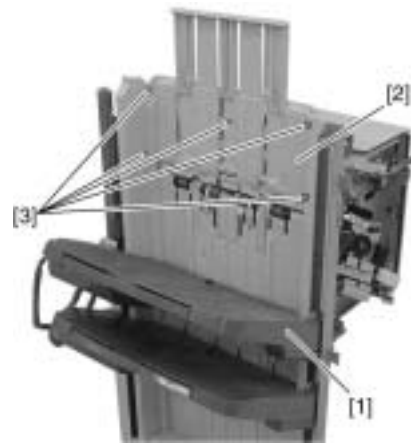

F-4-118

4.3.5.5 Removing the Tray 1

0004-4636

- ⚠** When you attach or remove the tray, please be sure to raise the shutter [1], release the latch [3] on the rear surface of the tray while the stack delivery gate [2] of the delivery opening is lifted (covered), and then move down the tray. If you move down the tray without lifting the shutter of the delivery opening, the stack delivery gate comes off from the Finisher. If the stack delivery gate comes off, remount it while paying attention so as not to lose the spring for the shaft of the stack delivery gate. The tray falls by its own weight when the latch is released, so be sure to hold the tray with hands.

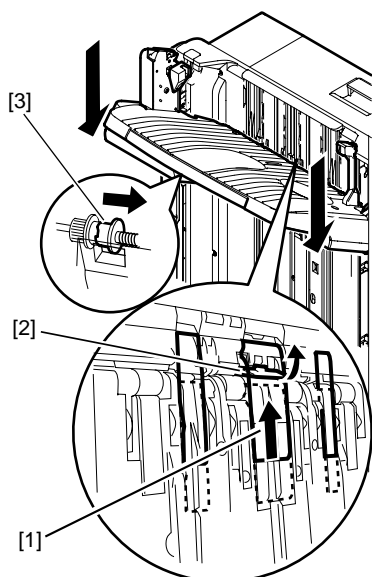

F-4-119

1) Remove screw [1] and remove the steel plate [2] and slide guide [3]. However, if the grate-shaped upper guide is removed, this step is not necessary.

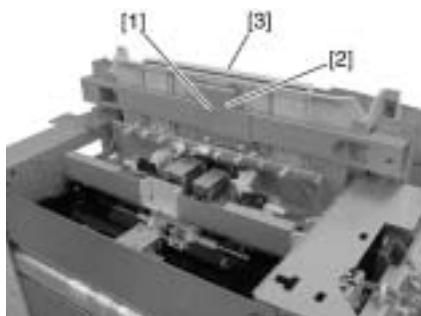

F-4-120

2) Remove screw [1] and remove the stopper [2].

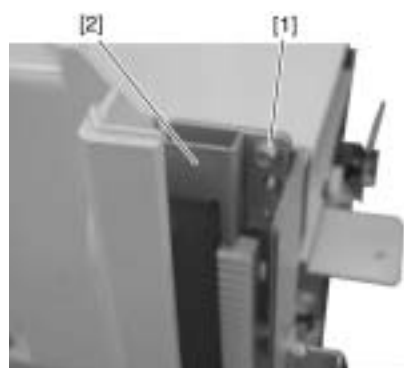

F-4-121

3) Remove two screws [1], open two harness retainers [2] and disconnect two connectors [3].

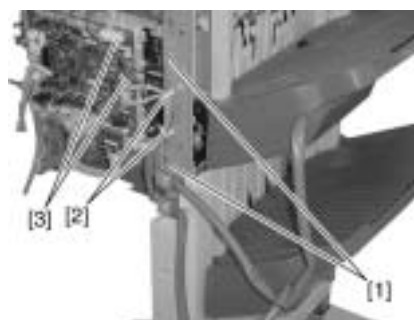

F-4-122

4) Insert your finger in the hole at the rear side of tray 1 [1], push the tray lift motor gear [2] to the front to release the clutch and lift tray 1 [1].

⚠ When the tray lift motor gear clutch is released, the tray drops by its own weight. Therefore, hold the tray with your hand when releasing the clutch. Also, be careful not to twist the tray cable when installing.

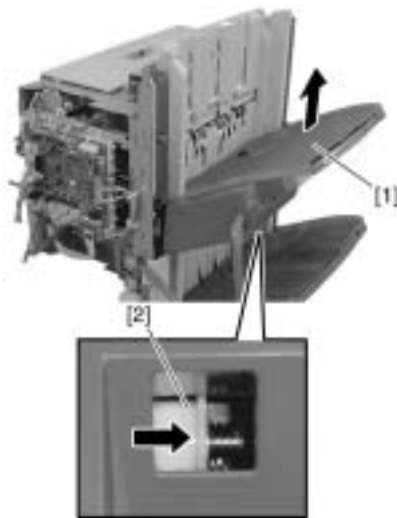

F-4-123

4.3.5.6 Removing the Tray 2 0004-4637

⚠ When you attach or remove the tray, please be sure to raise the shutter [1], release the latch [3] on the rear surface of the tray while the stack delivery gate [2] of the delivery opening is lifted (covered), and then move down the tray. If you move down the tray without lifting the shutter of the delivery opening, the stack delivery gate comes off from the Finisher. If the stack delivery gate comes off, remount it while paying attention so as not to lose the spring for the shaft of the stack delivery gate. The tray falls by its own weight when the latch is released, so be sure to hold the tray with hands.

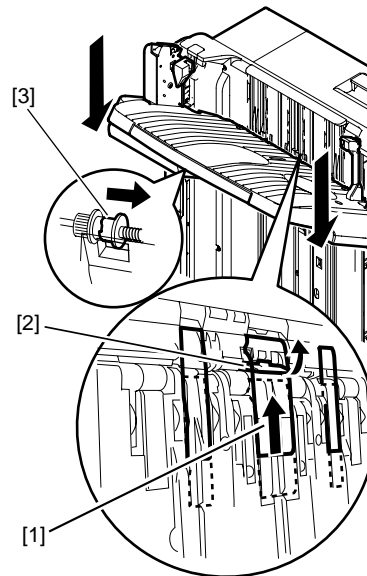

F-4-124

1) Remove screw [1] and remove the stopper [2].

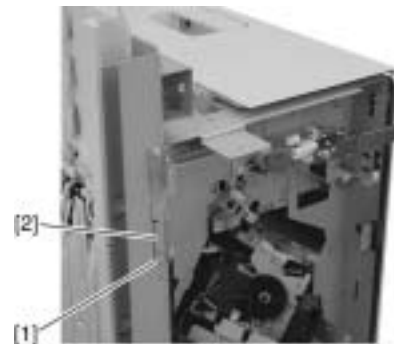

F-4-125

2) Remove two screws [1] and disconnect connector [2].

3) Insert your finger in the hole at the rear side of tray 2 [3], push the tray lift motor gear [4] to the front to release the clutch and lift tray 2 [3].

⚠ When the tray lift motor gear clutch is released the tray drops by its own weight. Therefore, hold the tray with your hand when releasing the clutch. Also, be careful not to twist the tray cable when installing.

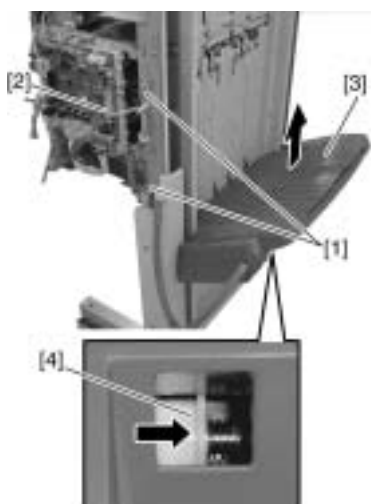

F-4-126

4.3.5.7 Removing the Grate-shaped Lower Guide

0004-4640

1) Remove ten screws [1] and remove the grate-shaped lower guide [2].

⚠ When replacing, be careful not to hook the grate-shaped lower guide to the sensor flag arm on the delivery side.

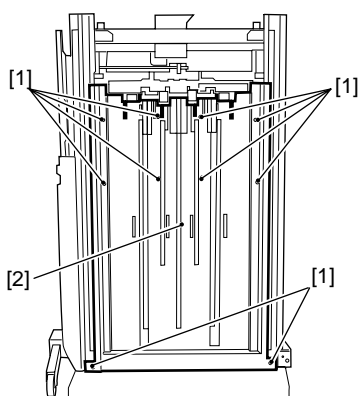

F-4-127

4.3.5.8 Removing the Processing Tray

0004-4645

1) Unfasten four snap fasteners [1] and remove the sensor flag [3] from the stack delivery roller [2].

⚠ Hold the snap fastener at the base when unfastening because the sensor flag arm can break easily. When fastening, insert the boss of the sensor flag snap fastener in the hole on the processing tray side.

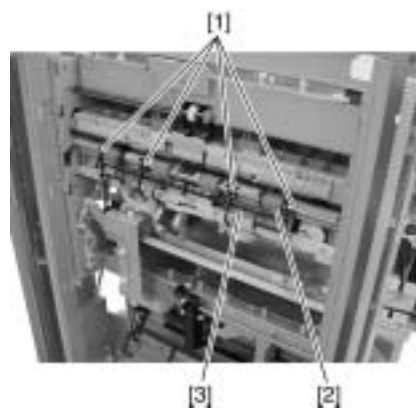

F-4-128

2) Remove the stack delivery roller front side E ring [1], gear [2], parallel pin [3], E ring [4], and bushing [5].

⚠ The parallel pin [3] drops when the gear [2] is removed. Be careful not to lose it.

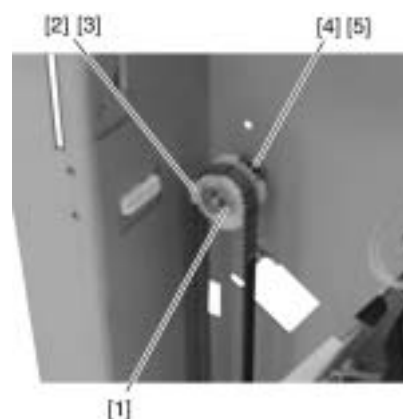

F-4-129

3) Remove all finisher controller PCB connectors [1].
4) Remove four screws [2]. Remove the screw [3]

securing the ground wire and remove the finisher controller PCB [4].

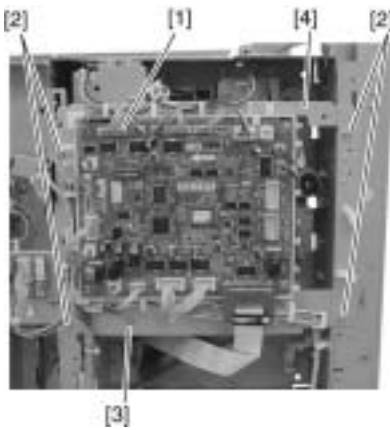

F-4-130

- 5) Release the claw [2] of the stack delivery roller rear side clutch [1] and remove the clutch [1].
- 6) Remove the E ring [3] and bushing [4] and remove the stack delivery roller.

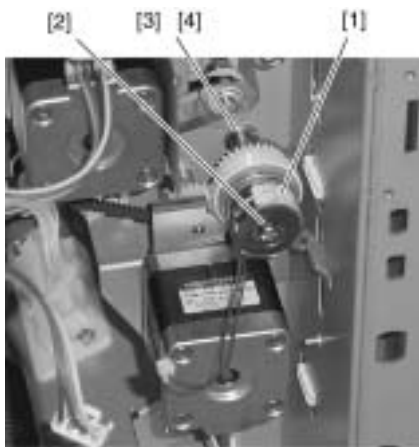

F-4-131

- 7) Disconnect the connector [1] and remove harness from the clamp and edge saddle [2].
- 8) Remove two screws [3] and pull out the processing tray [4] in the paper delivery direction.

⚠ When removing parts inside the processing tray, be careful not to exert force on the aligning plate (front/rear) or the rear end stopper plate.

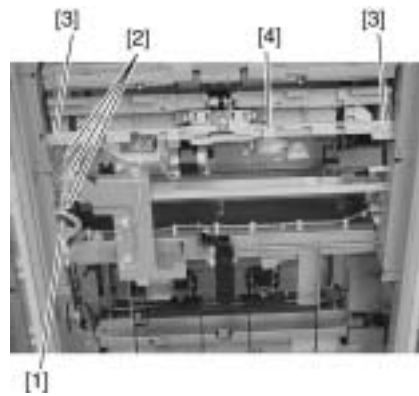

F-4-132

4.3.5.9 Removing the Return Roller

0004-4646

⚠ The return roller is subjected to special production processing known as "aging" to prevent possible increases in its feeding power. Do not clean the return roller. Cleaning (with water, for example), will increase its feed power, ultimately causing feeding faults.

Moreover, be sure to avoid touching the surface of the return roller when mounting it to the machine.

- 1) Remove two clips [1] of the return roller axis.
- 2) Pull out the return roller axis and remove two return rollers [2] together with collar.
- 3) Separate the return roller and collar.

⚠ Note the direction when installing the return roller.

Front side : Black

Rear side : White

The paper will not stack properly if it is installed in the wrong direction.

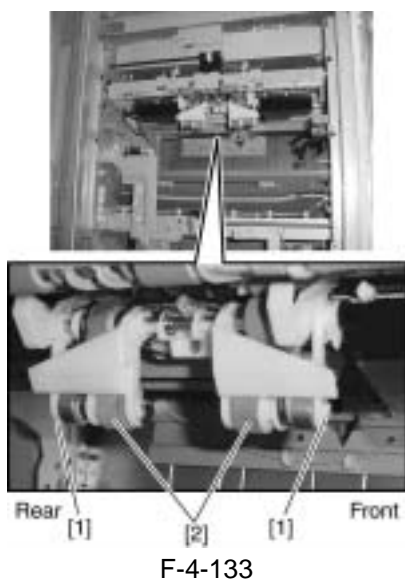

4.3.6 Return Roller Unit

4.3.6.1 Removing the Front Cover

0004-8078

- 1) Remove screw [1] and remove the foot cover [2].

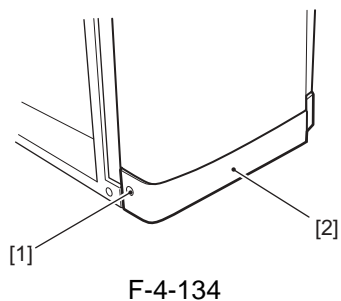

- 2) Open the front door [1] and remove three screws [2].
- 3) Remove the front cover [3].

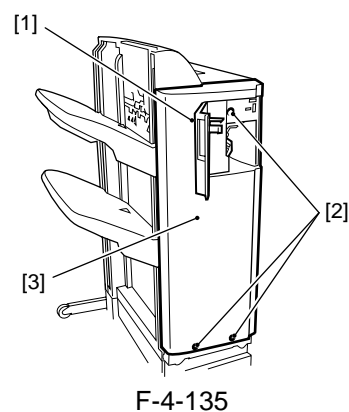

4.3.6.2 Removing the Rear Cover

0004-4656

- 1) Remove three screws [1] and remove the rear cover [2].

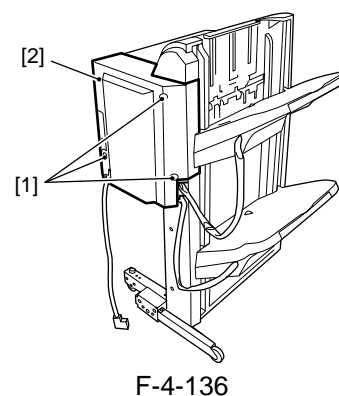

4.3.6.3 Removing the Left Upper Cover

0004-4659

- 1) Remove two screws [1].
- 2) With the upper door [2] open, remove the left upper cover [3] by tilting to the right.



F-4-137

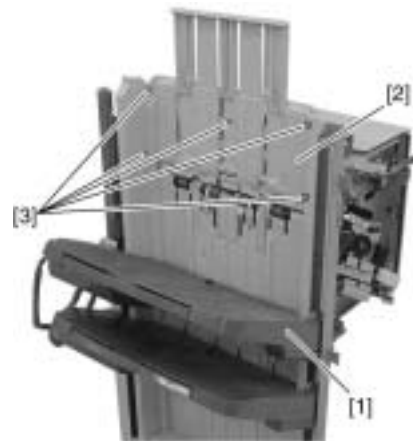

F-4-139

⚠ When replacing, hook the two claws [1] of the left upper cover to the steel plate.

4.3.6.5 Removing the Tray 1 0004-4663

⚠ When you attach or remove the tray, please be sure to raise the shutter [1], release the latch [3] on the rear surface of the tray while the stack delivery gate [2] of the delivery opening is lifted (covered), and then move down the tray. If you move down the tray without lifting the shutter of the delivery opening, the stack delivery gate comes off from the Finisher. If the stack delivery gate comes off, remount it while paying attention so as not to lose the spring for the shaft of the stack delivery gate. The tray falls by its own weight when the latch is released, so be sure to hold the tray with hands.



F-4-138

4.3.6.4 Removing the Grate-shaped Upper Guide 0004-4661

- 1) Lower tray [1] below the grate-shaped upper guide [2] (For how the tray is moved, see the steps under "Removing the Tray 1.").
- 2) Remove five screws [3] and remove the grate-shaped upper guide [2].

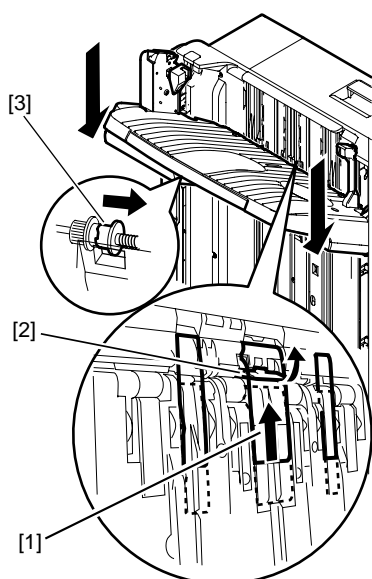

F-4-140

1) Remove screw [1] and remove the steel plate [2] and slide guide [3]. However, if the grate-shaped upper guide is removed, this step is not necessary.

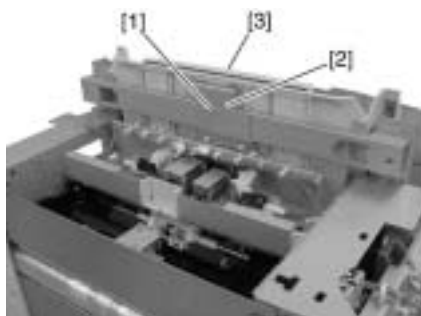

F-4-141

2) Remove screw [1] and remove the stopper [2].

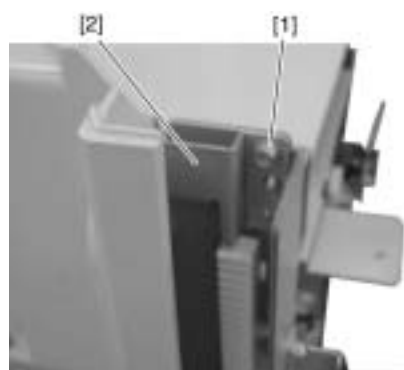

F-4-142

3) Remove two screws [1], open two harness retainers [2] and disconnect two connectors [3].

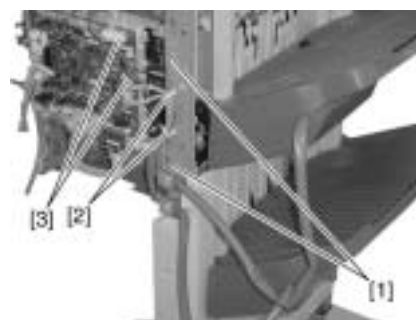

F-4-143

4) Insert your finger in the hole at the rear side of tray 1 [1], push the tray lift motor gear [2] to the front to release the clutch and lift tray 1 [1].

⚠ When the tray lift motor gear clutch is released, the tray drops by its own weight. Therefore, hold the tray with your hand when releasing the clutch. Also, be careful not to twist the tray cable when installing.

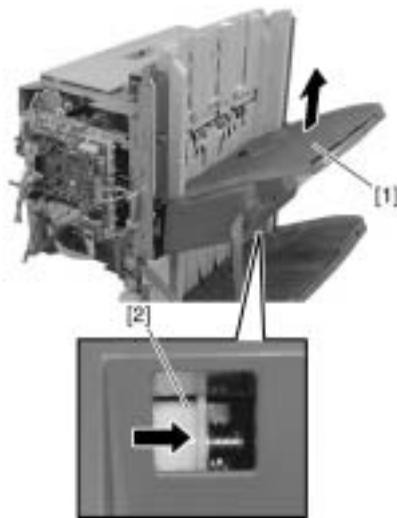

F-4-144

4.3.6.6 Removing the Tray 2 0004-4664

⚠ When you attach or remove the tray, please be sure to raise the shutter [1], release the latch [3] on the rear surface of the tray while the stack delivery gate [2] of the delivery opening is lifted (covered), and then move down the tray. If you move down the tray without lifting the shutter of the delivery opening, the stack delivery gate comes off from the Finisher. If the stack delivery gate comes off, remount it while paying attention so as not to lose the spring for the shaft of the stack delivery gate. The tray falls by its own weight when the latch is released, so be sure to hold the tray with hands.

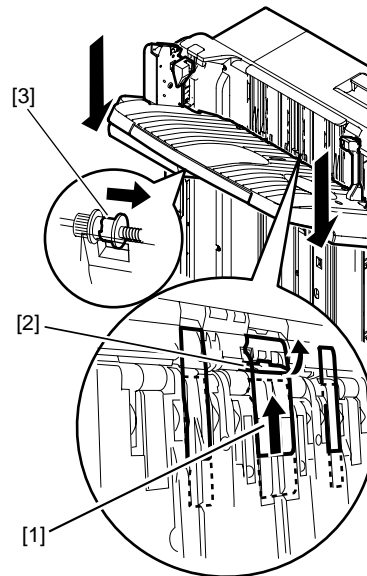

F-4-145

1) Remove screw [1] and remove the stopper [2].

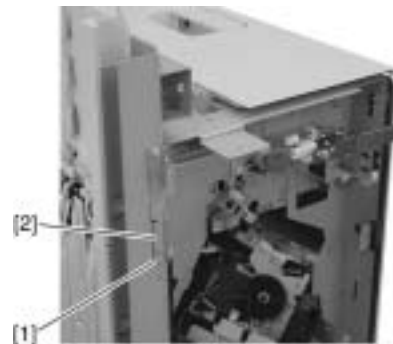

F-4-146

2) Remove two screws [1] and disconnect connector [2].

3) Insert your finger in the hole at the rear side of tray 2 [3], push the tray lift motor gear [4] to the front to release the clutch and lift tray 2 [3].

⚠ When the tray lift motor gear clutch is released the tray drops by its own weight. Therefore, hold the tray with your hand when releasing the clutch. Also, be careful not to twist the tray cable when installing.

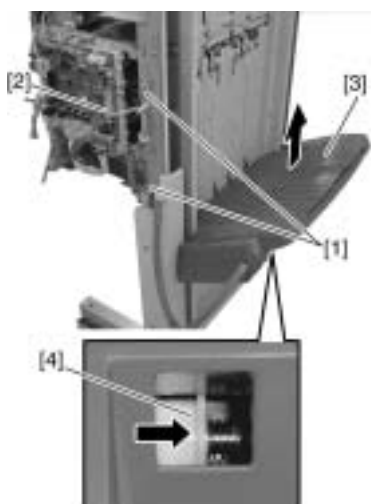

F-4-147

4.3.6.7 Removing the Grate-shaped Lower Guide

0004-4667

- 1) Remove ten screws [1] and remove the grate-shaped lower guide [2].

⚠ When replacing, be careful not to hook the grate-shaped lower guide to the sensor flag arm on the delivery side.

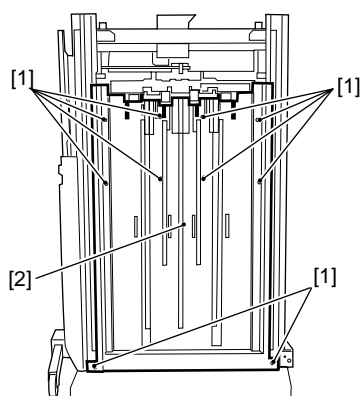

F-4-148

4.3.6.8 Removing the Stapler

0004-4669

- 1) Pull out the stapler, remove screw [1], and remove the PCB cover [2].

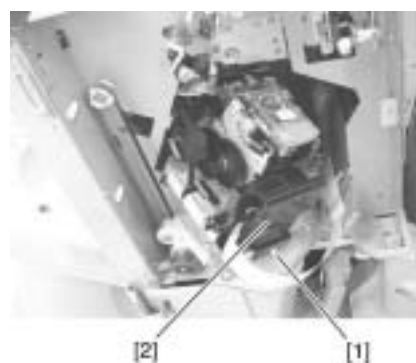

F-4-149

- 2) Release the claw [1] and remove the PCB [2].
- 3) Disconnect three connectors [3].
- 4) Remove screw [4] and remove the stapler together with the stapler base [5].

⚠ When removing, be careful not to damage the flag [6].

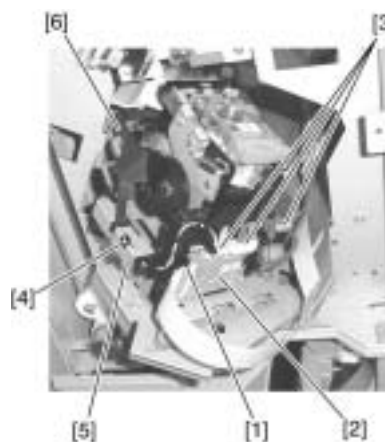

F-4-150

- 5) Turn the stapler over, disconnect two connectors [1], remove two screws [2], and remove the stapler from the stapler base.

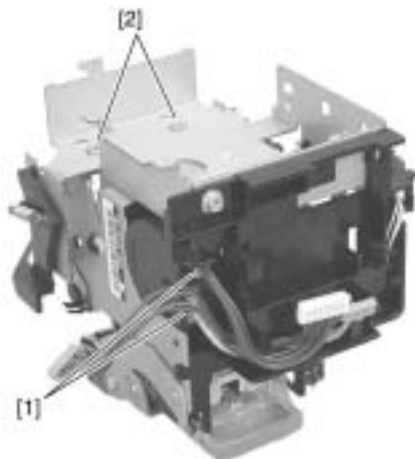

F-4-151

4.3.6.9 Removing the Processing Tray

0004-4671

1) Unfasten four snap fasteners [1] and remove the sensor flag [3] from the stack delivery roller [2].

⚠ Hold the snap fastener at the base when unfastening because the sensor flag arm can break easily. When fastening, insert the boss of the sensor flag snap fastener in the hole on the processing tray side.

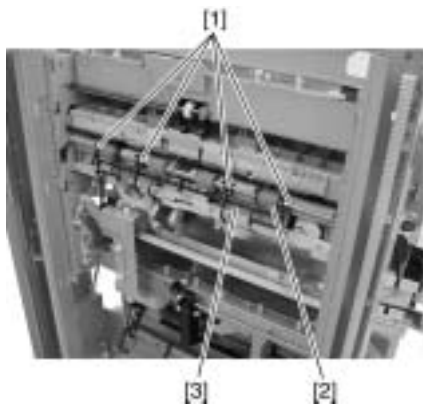

F-4-152

2) Remove the stack delivery roller front side E ring [1], gear [2], parallel pin [3], E ring [4], and bushing [5].

⚠ The parallel pin [3] drops when the gear [2] is removed. Be careful not to lose it.

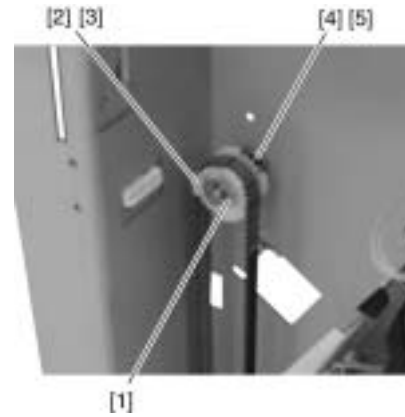

F-4-153

3) Remove all finisher controller PCB connectors [1].
 4) Remove four screws [2]. Remove the screw [3] securing the ground wire and remove the finisher controller PCB [4].

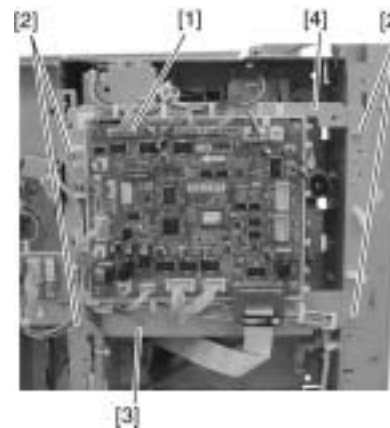

F-4-154

5) Release the claw [2] of the stack delivery roller rear side clutch [1] and remove the clutch [1].

6) Remove the E ring [3] and bushing [4] and remove the stack delivery roller.

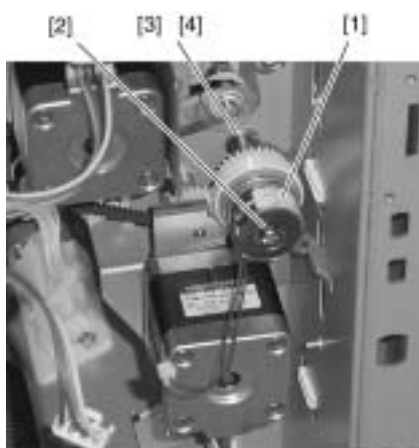

F-4-155

7) Disconnect the connector [1] and remove harness from the clamp and edge saddle [2].

8) Remove two screws [3] and pull out the processing tray [4] in the paper delivery direction.

⚠ When removing parts inside the processing tray, be careful not to exert force on the aligning plate (front/rear) or the rear end stopper plate.

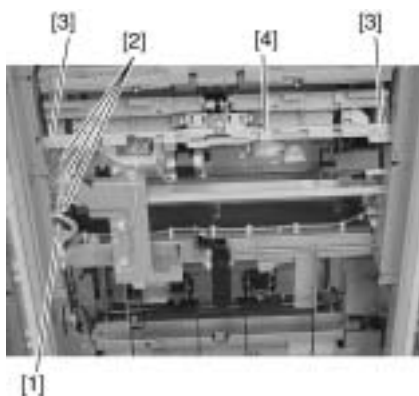

F-4-156

4.3.6.10 Removing the Swing Unit

0004-4673

1) Remove screw [1] and pull up the swing pressure guide [2].

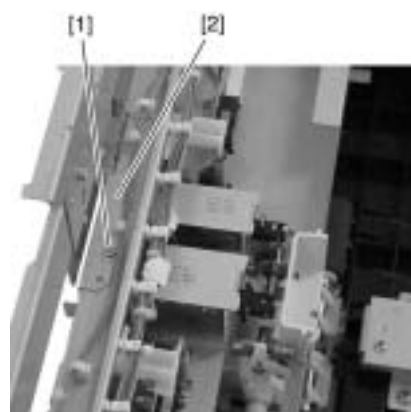

F-4-157

2) Remove two E rings [1] at the joint between the swing unit and the return roller unit and then slide the two return roller unit collars [2] inside.

3) Unhook the swing pressure rack [3] from the swing unit center hook.

4) Remove the belt on the gear [4] at the rear side of the swing unit and then pull out the swing unit [5] from the delivery direction.

⚠ The parallel pin [6] drops when the gear [4] is removed. Be careful not to lose it.

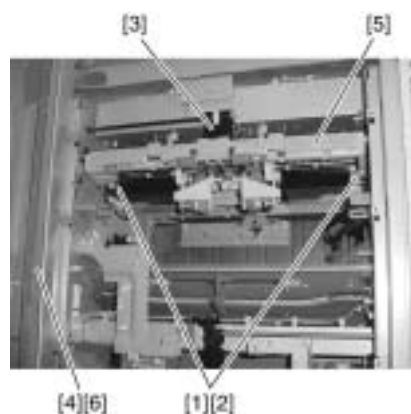

F-4-158

4.3.6.11 Removing the Return Roller Unit

0004-4677

1) Remove the return roller unit front side connector [1] and remove the clamp [2] from the harness.

2) Remove two screws [3] and pull out the return roller unit [4] from the front side.

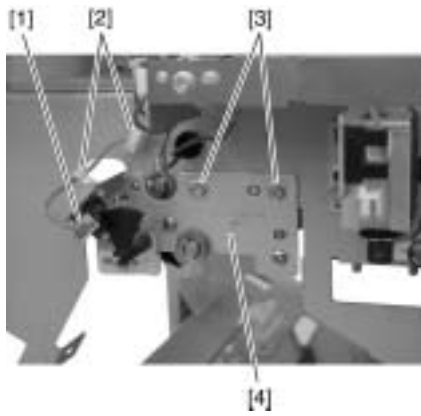

F-4-159

4.4 Electrical System

4.4.1 Finisher Controller PCB

4.4.1.1 Finisher Controller PCB

4.4.1.1.1 Removing the Rear Cover [0004-4682](#)

- 1) Remove three screws [1] and remove the rear cover [2].

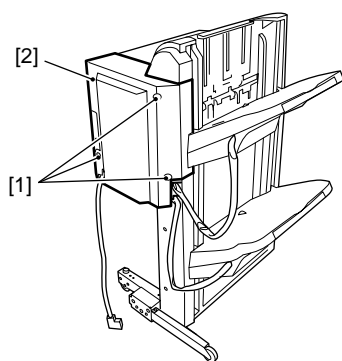

F-4-160

4.4.1.1.2 Removing the Finisher Controller PCB [0004-4683](#)

- 1) Disconnect all connectors [1] on the finisher controller PCB.
- 2) Remove four screws [2] and remove the finisher controller PCB [3].

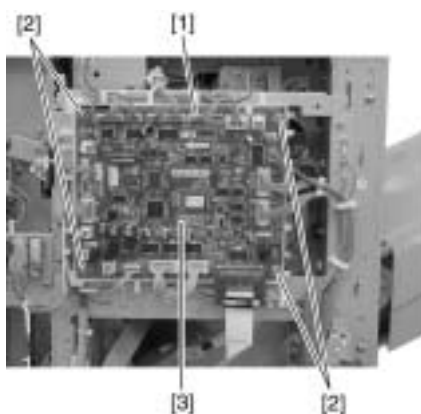

F-4-161

4.4.2 Static Charge Eliminator 1

4.4.2.1 Removing the Front Cover [0004-8080](#)

- 1) Remove screw [1] and remove the foot cover [2].

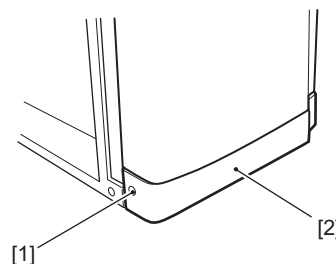

F-4-162

- 2) Open the front door [1] and remove three screws [2].
- 3) Remove the front cover [3].

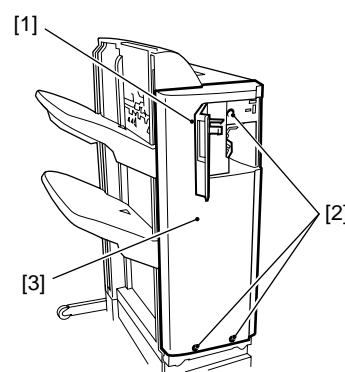

F-4-163

4.4.2.2 Removing the Rear Cover [0004-4695](#)

- 1) Remove three screws [1] and remove the rear cover [2].

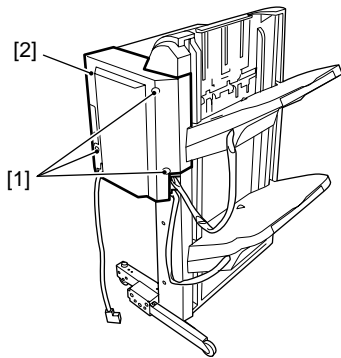

F-4-164

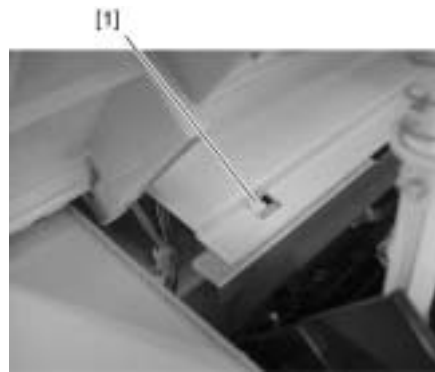

F-4-166

4.4.2.3 Removing the Left Upper Cover

0004-4696

- 1) Remove two screws [1].
- 2) With the upper door [2] open, remove the left upper cover [3] by tilting to the right.

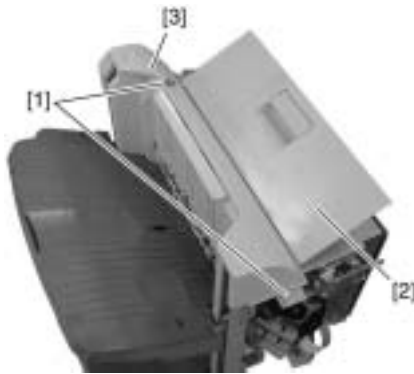

F-4-165

⚠ When replacing, hook the two claws [1] of the left upper cover to the steel plate.

4.4.2.4 Removing the Grate-shaped Upper Guide

0004-4700

- 1) Lower tray [1] below the grate-shaped upper guide [2] (For how the tray is moved, see the steps under "Removing the Tray 1.").
- 2) Remove five screws [3] and remove the grate-shaped upper guide [2].

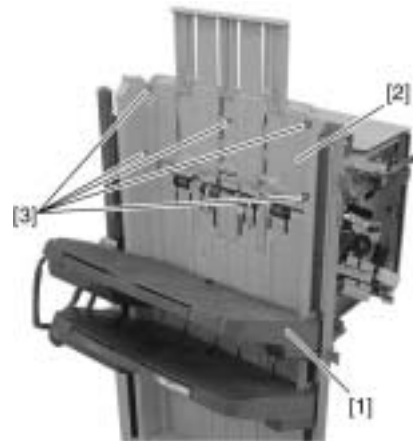

F-4-167

4.4.2.5 Removing the Tray 1

0004-4701

- ⚠** When you attach or remove the tray, please be sure to raise the shutter [1], release the latch [3] on the rear surface of the tray while the stack delivery gate [2] of the delivery opening is lifted (covered), and then move down the tray. If you move down the tray without lifting the shutter of the delivery opening, the stack delivery gate comes off from the

Finisher. If the stack delivery gate comes off, remount it while paying attention so as not to lose the spring for the shaft of the stack delivery gate. The tray falls by its own weight when the latch is released, so be sure to hold the tray with hands.

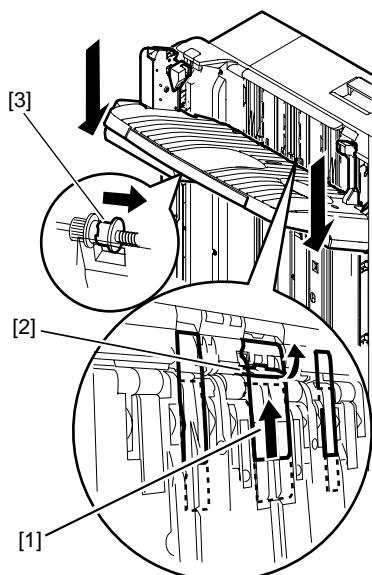

F-4-168

1) Remove screw [1] and remove the steel plate [2] and slide guide [3]. However, if the grate-shaped upper guide is removed, this step is not necessary.

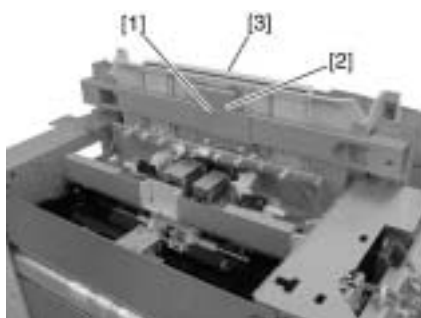

F-4-169

2) Remove screw [1] and remove the stopper [2].

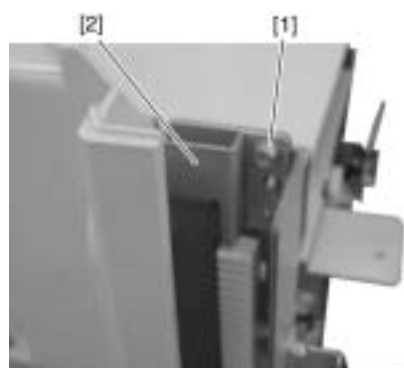

F-4-170

3) Remove two screws [1], open two harness retainers [2] and disconnect two connectors [3].

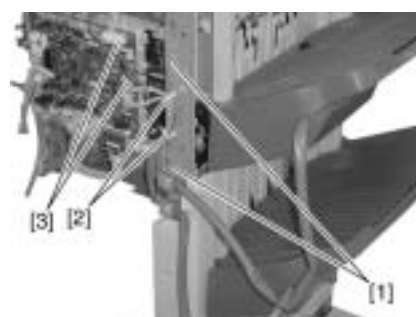

F-4-171

4) Insert your finger in the hole at the rear side of tray 1 [1], push the tray lift motor gear [2] to the front to release the clutch and lift tray 1 [1].

⚠ When the tray lift motor gear clutch is released, the tray drops by its own weight. Therefore, hold the tray with your hand when releasing the clutch. Also, be careful not to twist the tray cable when installing.

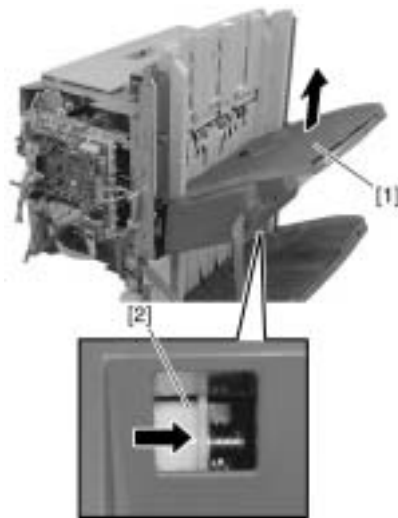

F-4-172

4.4.2.6 Removing the Tray 2 0004-4703

⚠ When you attach or remove the tray, please be sure to raise the shutter [1], release the latch [3] on the rear surface of the tray while the stack delivery gate [2] of the delivery opening is lifted (covered), and then move down the tray. If you move down the tray without lifting the shutter of the delivery opening, the stack delivery gate comes off from the Finisher. If the stack delivery gate comes off, remount it while paying attention so as not to lose the spring for the shaft of the stack delivery gate. The tray falls by its own weight when the latch is released, so be sure to hold the tray with hands.

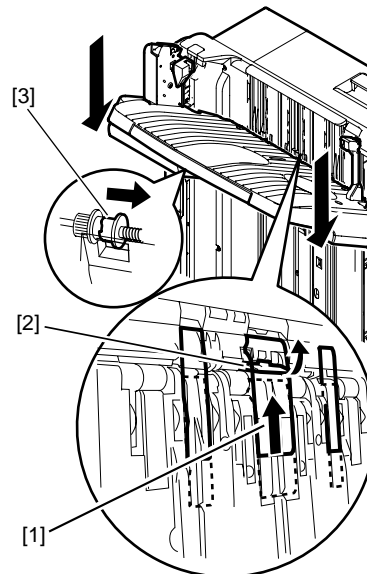

F-4-173

- 1) Remove screw [1] and remove the stopper [2].

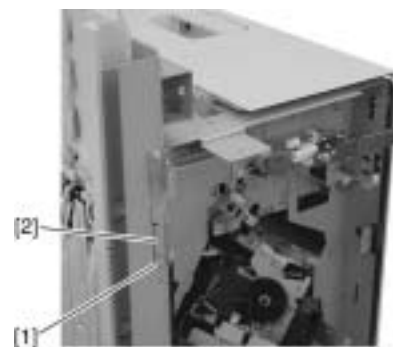

F-4-174

- 2) Remove two screws [1] and disconnect connector [2].
- 3) Insert your finger in the hole at the rear side of tray 2 [3], push the tray lift motor gear [4] to the front to release the clutch and lift tray 2 [3].

⚠ When the tray lift motor gear clutch is released the tray drops by its own weight. Therefore, hold the tray with your hand when releasing the clutch. Also, be careful not to twist the tray cable when installing.

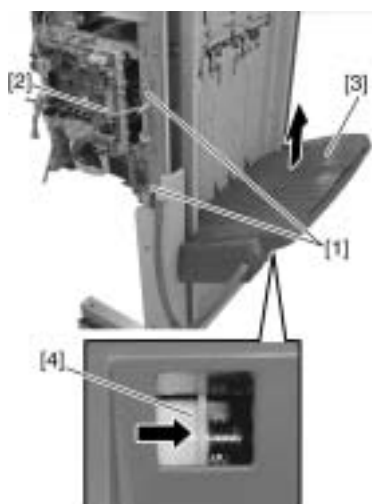

F-4-175

4.4.2.7 Removing the Grate-shaped Lower Guide

0004-4705

- 1) Remove ten screws [1] and remove the grate-shaped lower guide [2].

⚠ When replacing, be careful not to hook the grate-shaped lower guide to the sensor flag arm on the delivery side.

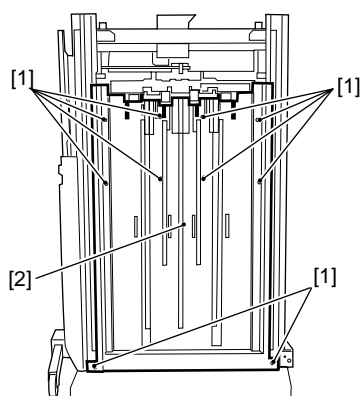

F-4-176

4.4.2.8 Removing the Stapler

0004-4707

- 1) Pull out the stapler, remove screw [1], and remove the PCB cover [2].

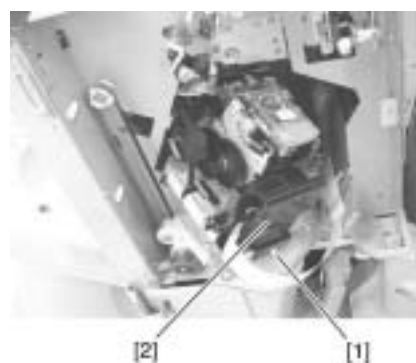

F-4-177

- 2) Release the claw [1] and remove the PCB [2].
- 3) Disconnect three connectors [3].
- 4) Remove screw [4] and remove the stapler together with the stapler base [5].

⚠ When removing, be careful not to damage the flag [6].

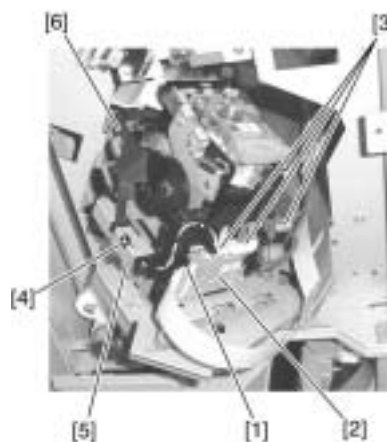

F-4-178

- 5) Turn the stapler over, disconnect two connectors [1], remove two screws [2], and remove the stapler from the stapler base.

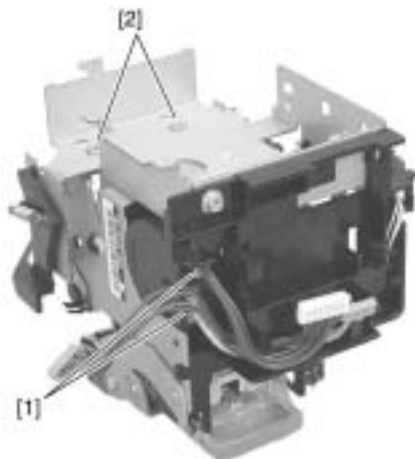

F-4-179

4.4.2.9 Removing the Processing Tray

[0004-4708](#)

1) Unfasten four snap fasteners [1] and remove the sensor flag [3] from the stack delivery roller [2].

⚠ Hold the snap fastener at the base when unfastening because the sensor flag arm can break easily. When fastening, insert the boss of the sensor flag snap fastener in the hole on the processing tray side.

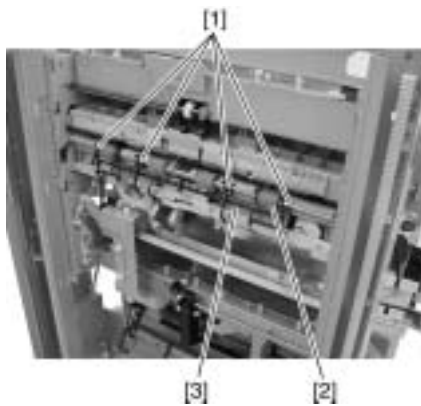

F-4-180

2) Remove the stack delivery roller front side E ring [1], gear [2], parallel pin [3], E ring [4], and bushing [5].

⚠ The parallel pin [3] drops when the gear [2] is removed. Be careful not to lose it.

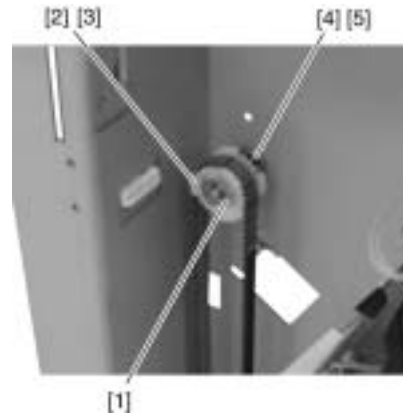

F-4-181

3) Remove all finisher controller PCB connectors [1].
 4) Remove four screws [2]. Remove the screw [3] securing the ground wire and remove the finisher controller PCB [4].

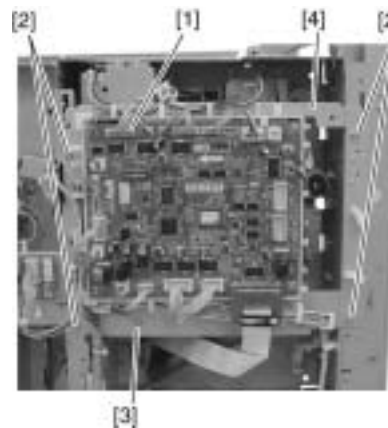

F-4-182

5) Release the claw [2] of the stack delivery roller rear side clutch [1] and remove the clutch [1].

6) Remove the E ring [3] and bushing [4] and remove the stack delivery roller.

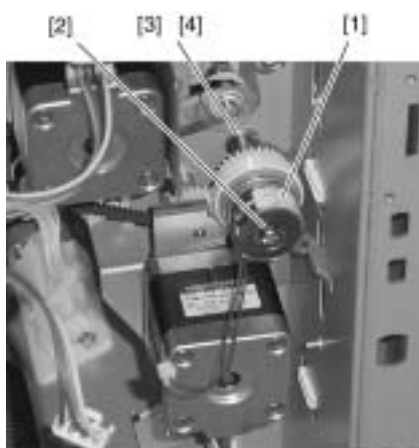

F-4-183

- 7) Disconnect the connector [1] and remove harness from the clamp and edge saddle [2].
- 8) Remove two screws [3] and pull out the processing tray [4] in the paper delivery direction.

⚠ When removing parts inside the processing tray, be careful not to exert force on the aligning plate (front/rear) or the rear end stopper plate.

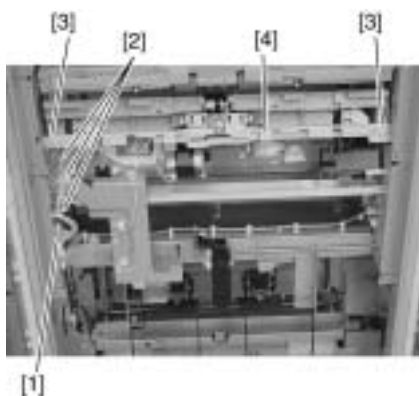

F-4-184

4.4.2.10 Removing the Swing

Unit Static Charge Eliminator [0004-4711](#)

- 1) Remove the screw [1] securing the static charge eliminator at the center of the swing unit.
- 2) Remove two screws [2] securing the ground of the delivery side static charge eliminator.

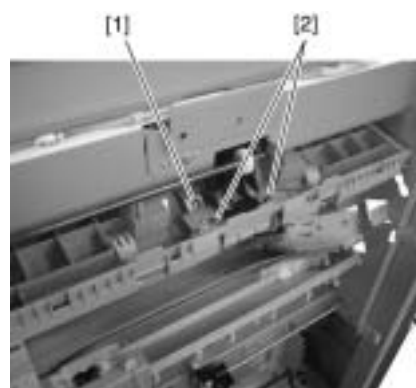

F-4-185

- 3) Pull out the static charge eliminator [1] at the center of the swing unit from the bottom.
- 4) Remove the four claws [2] securing the delivery side static charge eliminator and remove the two static charge eliminators [3].

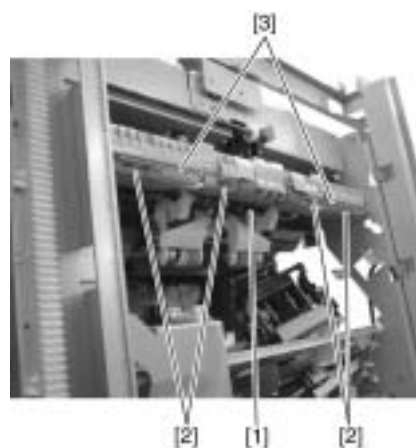

F-4-186

4.4.3 Static Charge Eliminator 2

4.4.3.1 Removing the Inlet

Static Charge Eliminator [0004-4713](#)

- 1) Open the upper door and unhook the hook linking the upper door and inlet upper guide.
- 2) Remove three screws [1] and remove the inlet static charge eliminator [2].

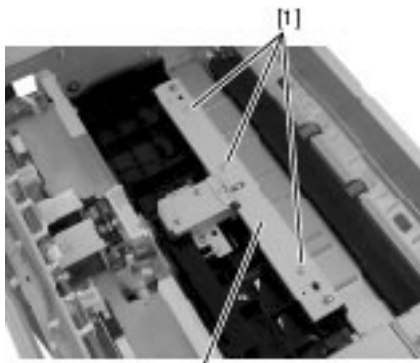

[2]
F-4-187

Chapter 5 Maintenance

Contents

5.1 User Maintenance	5-1
5.1.1 User Maintenance (Finisher Unit)	5-1
5.2 Maintenance and Inspection	5-2
5.2.1 Periodically Replaced Parts	5-2
5.2.1.1 Periodically Replaced Parts (Finisher Unit)	5-2
5.2.2 Durables	5-2
5.2.2.1 Durables (Finisher Unit)	5-2
5.2.3 Periodical Servicing	5-3
5.2.3.1 Periodical Servicing (Finisher Unit)	5-3
5.3 Adjustment	5-4
5.3.1 Adjustment at Time of Parts Replacement	5-4
5.3.1.1 Adjusting the Alignment Position	5-4
5.3.1.2 Adjusting the Staple Position	5-4
5.4 Troubleshooting	5-6
5.4.1 Error Code	5-6
5.4.1.1 E500;Communication error	5-6
5.4.1.2 E505;Backup RAM error	5-6
5.4.1.3 E514;Rear end assist motor error	5-6
5.4.1.4 E519;Gear change motor error	5-6
5.4.1.5 E530;Front aligning plate motor error	5-7
5.4.1.6 E531;Staple motor error	5-7
5.4.1.7 E532;Stapler shift motor error	5-7
5.4.1.8 E535;Swing motor error	5-8
5.4.1.9 E537;Rear aligning plate motor error	5-8
5.4.1.10 E540;Tray 1 shift motor error	5-9
5.4.1.11 E542;Tray 2 shift motor error	5-9
5.4.1.12 E584;Shutter malfunction	5-9
5.5 Outline of Electrical Components	5-11
5.5.1 Sensors (Finisher Unit)	5-11
5.5.2 Microswitches (Finisher Unit)	5-14
5.5.3 Solenoids (Finisher Unit)	5-15
5.5.4 Motors (Finisher Unit)	5-16
5.5.5 Clutches (Finisher Unit)	5-18
5.5.6 PCBs (Finisher Unit)	5-19
5.6 Variable Resistors (VR), Light-Emitting Diodes (LED), and Check Pins by PCB	5-21
5.6.1 Overview	5-21
5.6.2 Finisher Controller PCB	5-21
5.7 Upgrading	5-22
5.7.1 Upgrading (Finisher Unit)	5-22
5.8 Service Tools	5-30
5.8.1 Solvents and Oils	5-30

5.1 User Maintenance

5.1.1 User Maintenance (Finisher Unit)

0003-4569

T-5-1

No.	Item	Timing
1	Staple cartridge replacement	When prompted (indicator on host machine control panel)

5.2 Maintenance and Inspection

5.2.1 Periodically Replaced Parts

5.2.1.1 Periodically Replaced Parts (Finisher Unit)

0003-4571

The Finisher unit does not have parts that must be replaced on a periodical basis.

5.2.2 Durables

5.2.2.1 Durables (Finisher Unit)

0003-4573

Some of the parts of the machine may need to be replaced one or more times because of wear or tear during the machine's warranty period. Replace them as necessary.

T-5-2

As of May, 2003

No.	Name	No.	Quantity	Approx. life	Remark
1	Stapler	FM2-0665-000	1	500,000 times	1 cartridge lasts approximately 5,000 times
2	Delibery static charge eliminator (L)	FC5-3667-000	1	1,000,000 sheets	
3	Delibery static charge eliminator (R)	FC5-5571-000	1	1,000,000 sheets	
4	Inlet static charge eliminator	FL2-0822-000	1	1,000,000 sheets	
5	Swing guide inside static charge eliminator	FL2-0817-000	1	1,000,000 sheets	
6	Buffer roller	FC5-3442-000	2	1,000,000 sheets	

As of May, 2003					
No.	Name	No.	Quantity	Approx. life	Remark
7	Return roller (Rear)	FC5-3457- 000	1	1,000,000 sheets	Color;White
8	Return roller (Front)	FC5-6873- 000	1	1,000,000 sheets	Color;Black

5.2.3 Periodical Servicing

5.2.3.1 Periodical Servicing (Finisher Unit)

0003-4575

Does not have parts that must be serviced on a periodical basis.

5.3 Adjustment

5.3.1 Adjustment at Time of Parts Replacement

5.3.1.1 Adjusting the Alignment Position 0003-4577

Perform this adjustment after replacing the finisher controller PCB or when the alignment position must be changed for some reason.

- 1) Remove the rear cover of the finisher unit.
- 2) Check that the power of the host machine is off and set SW104 on the finisher controller PCB as follows according to the paper used for adjustment.

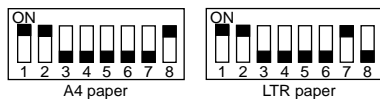

F-5-1

- 3) Turn on the power of the host machine.
- 4) Press SW103 on the finisher controller PCB.
When SW103 is pressed, the swing guide opens and the alignment plate moves to prescribed position.
- 5) Place ten sheets of A4/LTR paper between the alignment plates and push them against the stopper.
- 6) Press SW101 or SW102 on the finisher controller PCB and push the alignment plate against the paper.

When SW101 is pressed, alignment plate moves 0.42 mm forward.

When SW102 is pressed, alignment plate moves 0.42 mm backward.

- 7) When adjustment is complete, remove paper and press SW103 on the finisher controller PCB once to store the adjustment in memory.
- 8) Turn off all bits of finisher controller PCB SW104.
- 9) Turn off the power of the host machine and install the rear cover of the finisher unit.

5.3.1.2 Adjusting the Staple

Position 0003-4578

Perform this adjustment after replacing the finisher controller PCB or when the staple position must be changed for some reason. This adjustment adjusts the front/rear stitches with A4/A4R when the paper used for adjustment is AB type and with LTR/LTRR when the paper is INCH type.

- 1) Remove the rear cover of the finisher unit.
- 2) Check that the host machine power is off and set SW104 on the finisher controller PCB as follows according to paper/stitch position used for adjustment.

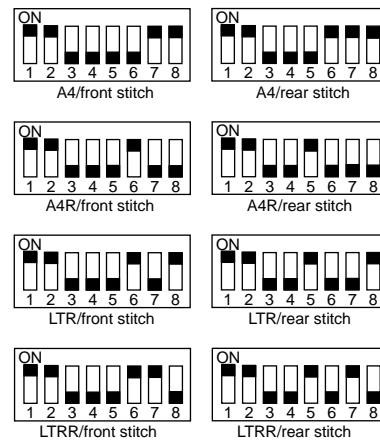

F-5-2

- 3) Turn on the host machine power.
- 4) Press SW103 on the finisher controller PCB.

When SW103 is pressed, the swing guide opens and the alignment plate moves to prescribed position.

- 5) Place a sheet of paper between the alignment plates, push it against the stopper, and push the rear edge of the paper against the rear alignment plate.

If the gap between the front alignment plate and front edge of the paper is 1 mm or greater, end staple position adjustment and repeat staple position adjustment after completing alignment plate adjustment.

- 6) Press SW103 on the finisher controller PCB once to staple. However, remove the stapled paper manually to verify the staple position because it is not ejected.
- 7) Press SW103 on the finisher controller PCB once.

8) If the staple position is correct, insert a sheet of paper between the aligning plates and push it against the stopper, push the far end edge of the paper to the rear aligning plate, and press SW103 once (stapling action/store adjustment value) and proceed to step 11).

9) To adjust the staple position, press SW101 or SW102 on the finisher controller PCB and adjust the staple position.

When SW101 is pressed, staple position moves 0.49 mm forward.

When SW102 is pressed, staple position moves 0.49 mm backward.

10) Repeat steps 5) and 6) and check that the staple position is adjusted correctly.

11) Turn off all bits of SW104 on the finisher controller PCB.

12) Turn off the power of the host machine and install the rear cover of the finisher unit.

5.4 Troubleshooting

5.4.1 Error Code

5.4.1.1 E500;Communication error

0003-7585

Finisher controller PCB/Host machine DC controller PCB

1) Does it improve when the host machine power switch is turned OFF/ON?

YES : End

Wiring

2) Is the wiring between the finisher controller PCB and host machine DC controller PCB normal?

NO : Repair the wiring.

Finisher controller PCB/Host machine DC controller PCB

3) Does it improve when the finisher controller PCB and host machine DC controller PCB are replaced?

YES : End

5.4.1.2 E505;Backup RAM error

0003-4583

Finisher controller PCB

1) Does it improve when the host machine power switch is turned OFF/ON?

YES : End

2) Does it improve when the finisher controller PCB are replaced?

YES: End

5.4.1.3 E514;Rear end assist motor error

0003-4592

Rear end assist guide home position sensor (PI39)

1) Check the rear end assist guide home position sensor. Does the sensor operate normally?

NO : Replace the sensor.

Wiring

2) Is the wiring between the finisher controller PCB and rear end assist motor normal?

NO : Repair the wiring.

Rear end assist mechanism

3) Is there any abnormality in the rear end assist mechanism?

YES : Repair the rear end assist mechanism.

Rear end assist motor (M39)/Finisher controller PCB

4) Does it improve when the rear end assist motor is replaced?

YES : End

NO : Replace the finisher controller PCB.

5.4.1.4 E519;Gear change motor error

0003-4593

Gear change home position sensor (PI49)

1) Check the gear change home position sensor. Does the sensor operate nor-mally?

NO : Replace the sensor.

Wiring

2) Is the wiring between the finisher controller PCB and Gear change motor normal?

NO : Repair the wiring.

Gear change mechanism

3) Is there any abnormality in the gear change mechanism?

YES : Repair the gear change mechanism.

Gear change motor (M40)/Finisher controller PCB

4) Does it improve when the gear change motor is replaced?

YES : End

NO : Replace the finisher controller PCB.

5.4.1.5 E530;Front aligning plate motor error

0003-4584

Front aligning plate home position sensor (PI36)

1) Check the front aligning plate home position sensor. Does the sensor operate normally?

NO : Replace the sensor.

Wiring

2) Is the wiring between the finisher controller PCB and front aligning plate motor normal?

NO : Repair the wiring.

Front aligning plate

3) Is there any mechanical trapping in the path of the aligning plate?

YES : Repair the mechanism.

Front aligning plate motor (M33)/Finisher controller PCB

4) Does it improve when the front aligning plate motor is replaced?

YES : End

NO : Replace the finisher controller PCB.

5.4.1.6 E531;Staple motor error

0003-4586

Wiring

1) Is the wiring between the finisher controller PCB and stapler normal?

NO : Repair the wiring.

Stapler/Finisher controller PCB

2) Does it improve when the stapler is replaced?

YES : End

NO : Replace the finisher controller PCB.

5.4.1.7 E532;Stapler shift motor error

0003-4587

Stapler drive home position sensor (PI40)

1) Check the stapler drive home position sensor. Does it operate normally?

NO : Replace the sensor.

Wiring

2) Is the wiring between the finisher controller PCB and stapler shift motor normal?

NO : Repair the wiring.

Stapler shift base

3) Is there mechanical trapping in the path of the stapler shift base?

YES : Repair the mechanism.

Stapler shift motor (M35)/Finisher controller PCB

4) Does it improve when the stapler shift motor is replaced?

YES : End

NO : Replace the finisher controller PCB.

5.4.1.8 E535;Swing motor error

0003-4588

Swing home position sensor (PI35)

1) Check the swing home position sensor. Does the sensor operate normally?

NO : Replace the sensor.

Wiring

2) Is the wiring between the finisher controller PCB and swing motor normal?

NO : Repair the wiring.

Swing mechanism

3) Is there any abnormality in the swing mechanism?

YES : Repair the swing mechanism.

Swing motor (M36)/Finisher controller PCB

4) Does it improve when the swing motor is replaced?

YES : End

NO : Replace the finisher controller PCB.

5.4.1.9 E537;Rear aligning plate motor error

0003-4585

Rear aligning plate home position sensor (PI37)

1) Check the rear aligning plate home position sensor. Does the sensor operate normally?

NO : Replace the sensor.

Wiring

2) Is the wiring between the finisher controller PCB and rear aligning plate motor normal?

NO : Repair the wiring.

Rear aligning plate

3) Is there mechanical trapping in the path of the aligning plate?

YES : Repair the mechanism.

Rear aligning plate motor (M34)/Finisher controller PCB

4) Does it improve when the rear aligning plate motor is replaced?

YES : End

NO : Replace the finisher controller PCB.

5.4.1.10 E540;Tray 1 shift motor error

0003-4589**Tray 1 shift area sensor PCB**

1) Check the tray 1 shift area sensors 1 to 3. Do the sensors operate normally?

NO : Replace the tray 1 shift area sensor PCB.

Wiring

2) Is the wiring between the finisher controller PCB and tray 1 shift motor normal?

NO : Repair the wiring.

Tray up/down mechanism

3) Is there any abnormality in the tray up/down mechanism?

YES : Repair the tray up/down mechanism.

Tray 1 shift motor (M37)/Finisher controller PCB

4) Does it improve when the tray 1 shift motor is replaced?

YES : End

NO : Replace the finisher controller PCB.

5.4.1.11 E542;Tray 2 shift motor error

0003-4590**Saddle delivery tray unit**

1) Is the saddle delivery tray unit closed properly (not closed on one side)?

NO : Properly close the saddle delivery tray unit.

Tray 2 shift area sensor PCB

2) Check the tray 2 shift area sensors 1 to 3. Do the sensors operate normally?

NO : Replace the tray 2 shift area sensor PCB

Wiring

3) Is the wiring between the finisher controller PCB and tray 2 shift motor normal?

NO : Repair the wiring.

Tray up/down mechanism

4) Is there any abnormality in the tray up/down mechanism?

YES : Repair the tray up/down mechanism.

Tray 2 shift motor (M38)/Finisher controller PCB

5) Does it improve when the tray 2 shift motor is replaced?

YES : End

NO : Replace the finisher controller PCB.

5.4.1.12 E584;Shutter malfunction

0003-4591**Shutter home position sensor (PI45)**

1) Check the shutter home position sensor. Does the sensor operate normally?

NO : Replace the sensor.

Wiring

2) Is the wiring between the finisher controller PCB and stack ejection motor, and between the finisher controller PCB and shutter clutch normal?

NO : Repair the wiring.

Shutter mechanism

3) Is there any abnormality in the shutter mechanism?

YES : Repair the shutter mechanism.

Stack ejection motor (M32)/Shutter clutch (CL31)/Finisher controller PCB

4) Does it improve when the stack ejection motor and shutter clutch are replaced?

YES : End

NO : Replace the finisher controller PCB.

5.5 Outline of Electrical Components

5.5.1 Sensors (Finisher Unit)

0005-7225

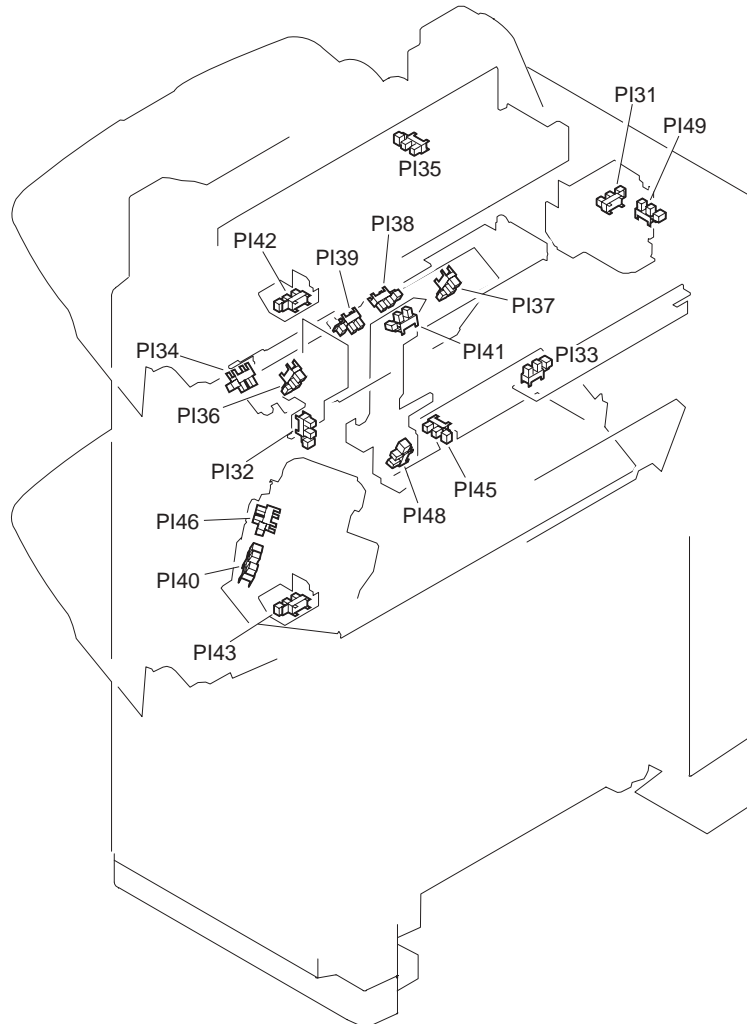

F-5-3

T-5-3

Ref.	Name	Description	Parts number	JAM	Error
PI31	Upper cover sensor	Detects upper cover open/close	WG8-5593	1400	
PI32	Front cover sensor	Detects front cover open/close	WG8-5593	1400/ 1788	

Ref.	Name	Description	Parts number	JAM	Error
PI33	Inlet sensor	Detects paper in inlet	WG8-5593	1001/ 1101/ 1200/ 1300	
PI34	Feed path sensor	Detects paper in feed path	WG8-5593	1004/ 1104/ 1300	
PI35	Swing guide home position sensor	Detects swing guide HP	WG8-5593		E535
PI36	Front aligning plate home position sensor	Detects aligning plate front HP	WG8-5593		E530
PI37	Rear aligning plate home position sensor	Detects aligning plate rear HP	WG8-5593		E537
PI38	Processing Tray sensor	Detects paper in processing tray	WG8-5593		
PI39	Rear end assist guide home position sensor	Detects rear end assist HP	WG8-5593		E514
PI40	Stapler shift home position sensor	Detects stapler HP	WG8-5593		E532
PI41	Paper surface sensor	Detects paper surface	WG8-5593		
PI42	Tray 1 paper sensor	Detects paper on tray 1	WG8-5593		
PI43	Tray 2 paper sensor	Detects paper on tray 2	WG8-5593		
PI45	Shutter home position sensor	Detects shutter HP	WG8-5593		E584
PI46	Stapler alignment interference sensor	Detects stapler alignment interference	WG8-5593		
PI48	Tray 2 paper surface sensor	Detects paper surface on tray 2	WG8-5593		
PI49	Gear change home position sensor	Detects gear change HP	WG8-5593		E519

T-5-4

Ref.	Stapler PCB2	Stapler PCB1	Finisher controller PCB
PI31			J708

Ref.	Stapler PCB2	Stapler PCB1	Finisher controller PCB
PI32			J707
PI33			J708
PI34			J707
PI35			J707
PI36			J722
PI37			J722
PI38			J722
PI39			J722
PI40			J721
PI41			J721
PI42			J711
PI43			J716
PI45			J721
PI46	J994 / J993	J992 / J991	J717
PI48			J721
PI49			J708

5.5.2 Microswitches (Finisher Unit)

0005-7226

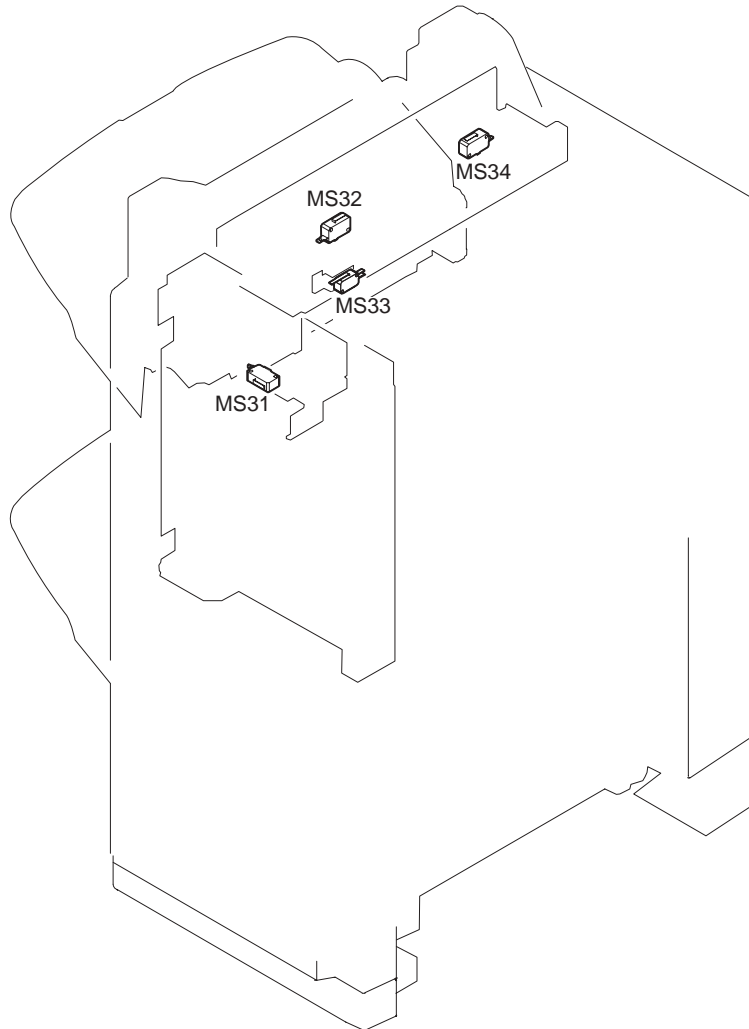

F-5-4

T-5-5

Ref.	Name	Description	Parts number	JAM	Error	Finisher controller PCB
MS3 1	Front cover switch	Detects front cover close	FH7-6379	140 0	E5F9	J719
MS3 2	Swing guide switch	Detects swing guide open	FH7-6379			J715

Ref.	Name	Description	Parts number	JAM	Error	Finisher controller PCB
MS33	Tray 1 switch	Detects tray 1	FH7-6377			J714
MS34	Staple safety switch	Detects swing guide open	FH7-6379			J715

5.5.3 Solenoids (Finisher Unit)

0005-7227

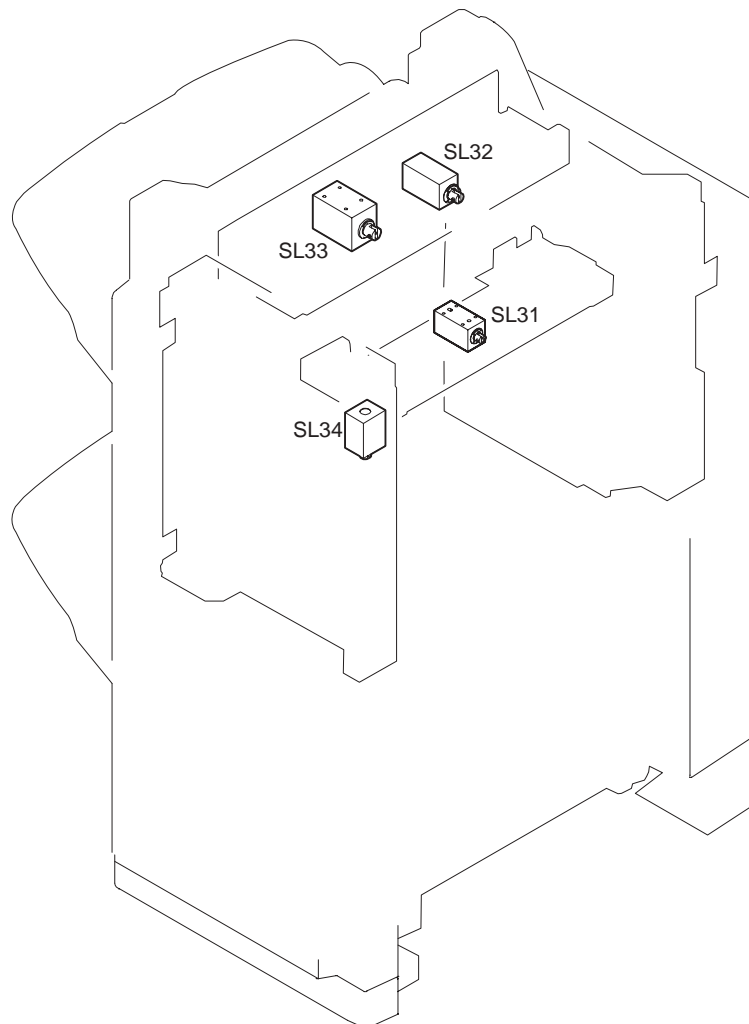

F-5-5

T-5-6

Ref.	Name	Parts number	Error	Finisher controller PCB
SL31	Inlet roller separation solenoid	FL2-0811	E584	J710
SL32	Buffer roller separation solenoid	FL2-0813		J710
SL33	1st delivery roller separation solenoid	FL2-0812		J710
SL34	Buffer rear end holding solenoid	FL2-0821		J710

5.5.4 Motors (Finisher Unit)

0005-7228

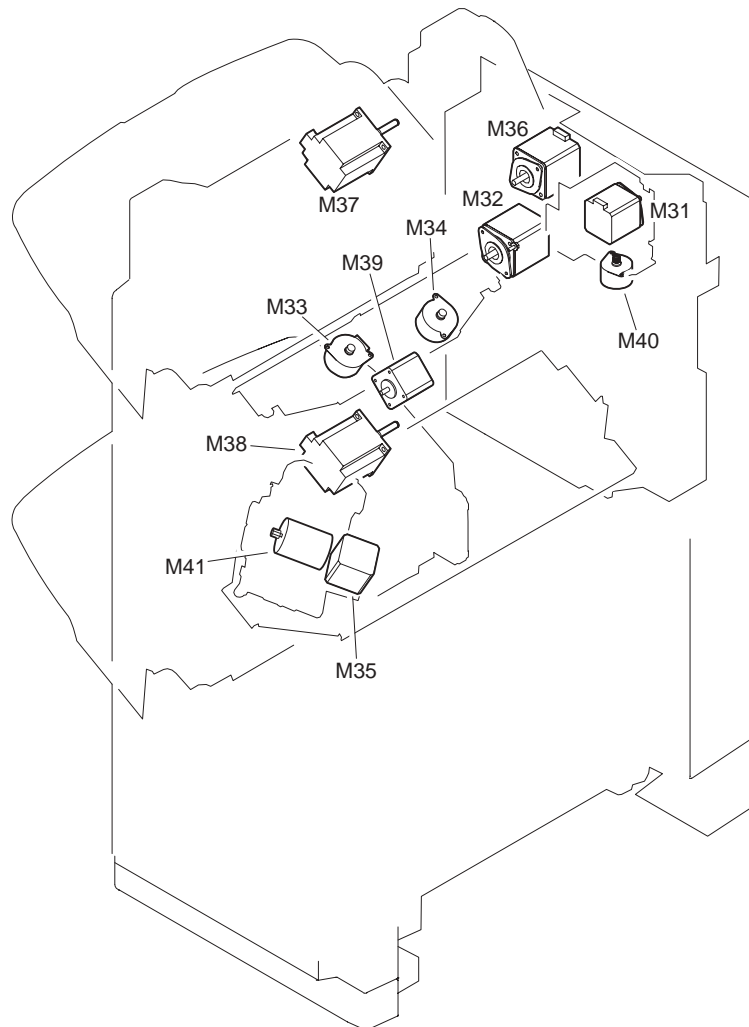

F-5-6

T-5-7

Ref.	Name	Parts number	Error
M31	Inlet motor	FH5-1034	
M32	Stack ejection motor	FH5-1035	E584
M33	Front aligning plate motor	FH5-1040	E530
M34	Rear aligning plate motor	FH5-1040	E537
M35	Stapler shift motor	FH5-1037	E532
M36	Swing motor	FH5-1036	E535
M37	Tray 1 shift motor	FH5-1038	E540
M38	Tray 2 shift motor	FH5-1038	E542
M39	Rear end assist motor	FH5-1039	E514
M40	Gear change motor	FH5-1041	E519
M41	Staple motor	FM2-0665	E531

T-5-8

Ref.	Tray1 driver PCB	Stapler PCB2	Stapler PCB1	Tray2 driver PCB	Finisher controller PCB
M31					J718
M32					J713
M33					J722
M34					J722
M35		J995 / J993	J992 / J991		J717
M36					J709
M37	J952 / J951				J711
M38				J1953 / J1951	J716
M39					J722
M40					J708
M41		J994,995 / J993	J992 / J991		J717

5.5.5 Clutches (Finisher Unit)

0005-7229

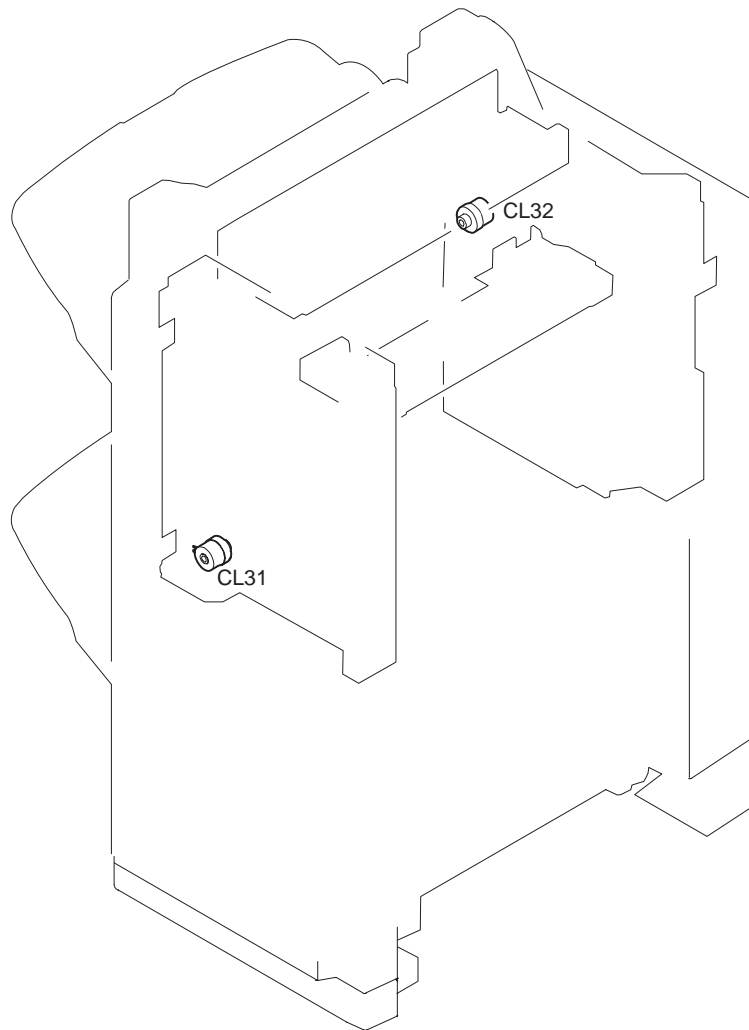

F-5-7

T-5-9

Ref.	Description	Parts number	Error	Finisher controller PCB
CL3 1	Shutter clutch	FH6-5101	E584	J721
CL3 2	Stack ejection lower roller clutch	FH6-5101		J712

5.5.6 PCBs (Finisher Unit)

0005-7230

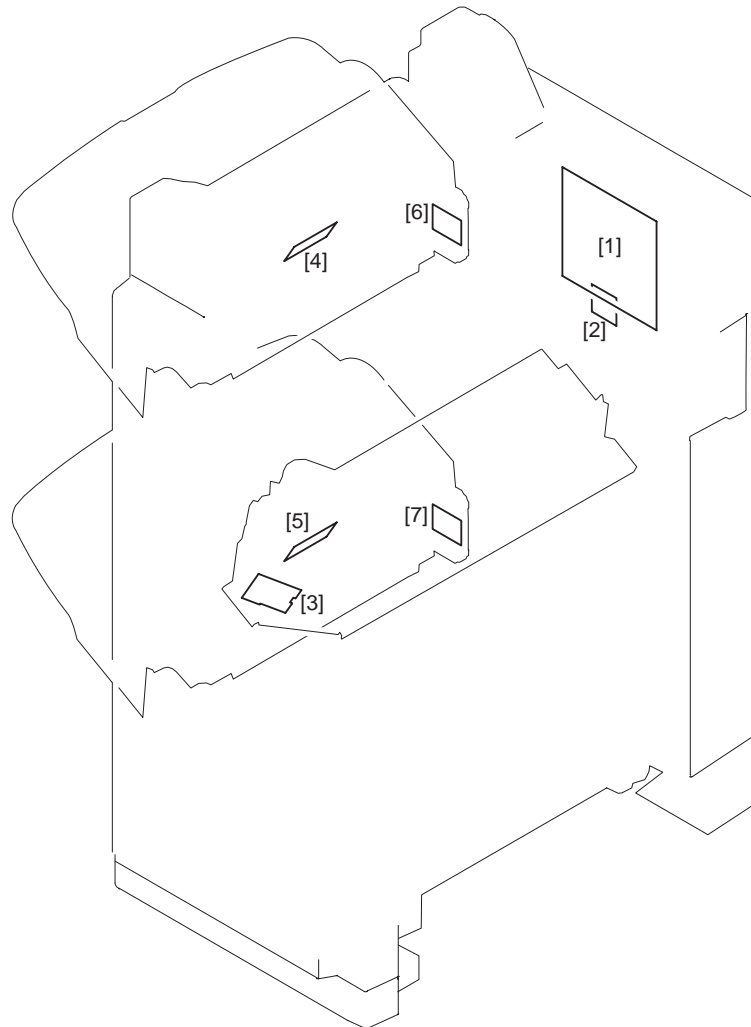

F-5-8

T-5-10

Ref.	Name	Parts number	Error
[1]	Finisher controller PCB	FG3-2883	
[2]	Stapler PCB1	FM2-1426(CABLE, STAPLE CONNECTING ASS'Y)	
[3]	Stapler PCB2	FM2-1426(CABLE, STAPLE CONNECTING ASS'Y)	
[4]	Tray1 driver PCB	FG3-2887	
[5]	Tray2 driver PCB	FG3-2887	
[6]	Tray1 shift area sensor PCB	FG3-2886	E540

Ref.	Name	Parts number	Error
[7]	Tray2 shift area sensor PCB	FG3-2886	E542

5.6 Variable Resistors (VR), Light-Emitting Diodes (LED), and Check Pins by PCB

5.6.1 Overview

0003-4614

Of the LEDs and check pins used in the machine, those needed during servicing in the field are discussed.

⚠ Do not touch the check pins not found in the list herein. They are exclusively for factory use, and require special tools and a high degree of accuracy.

5.6.2 Finisher Controller PCB

0003-4615

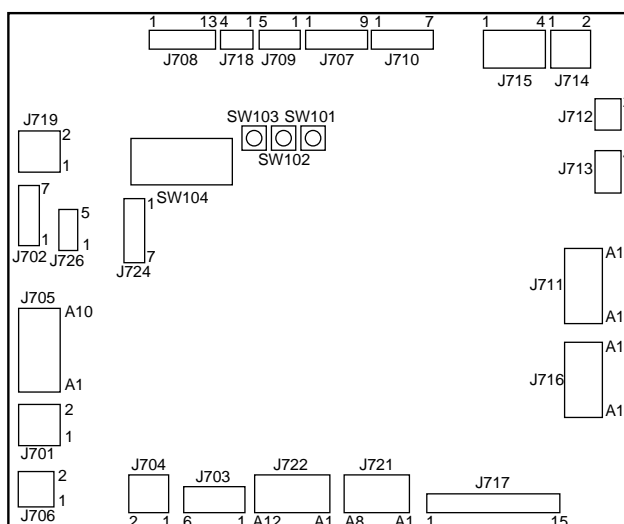

F-5-9

T-5-11

Switch	Switch Function
SW101	Used for making adjustments to the alignment position/stapling position.
SW102	Used for making adjustments to the alignment position/stapling position.
SW103	Used to start operation for alignment position adjustment/stapling position adjustment.
SW104	Used to start operation for alignment position adjustment/stapling position adjustment.

5.7 Upgrading

5.7.1 Upgrading (Finisher Unit)

0003-8837

Overview

A flash ROM is used for the IC101 (CPU) of the Finisher unit. To upgrade this IC, the downloader PCB (FY9-2034) is used. The operating instructions for it are given below.

How to Use the Downloader PCB (FY9-2034)

1. When to Use the Downloader PCB

The downloader PCB is used when upgrading the CPU (IC101) of the Finisher Controller PCB.

2. Member part of the downloader PCB

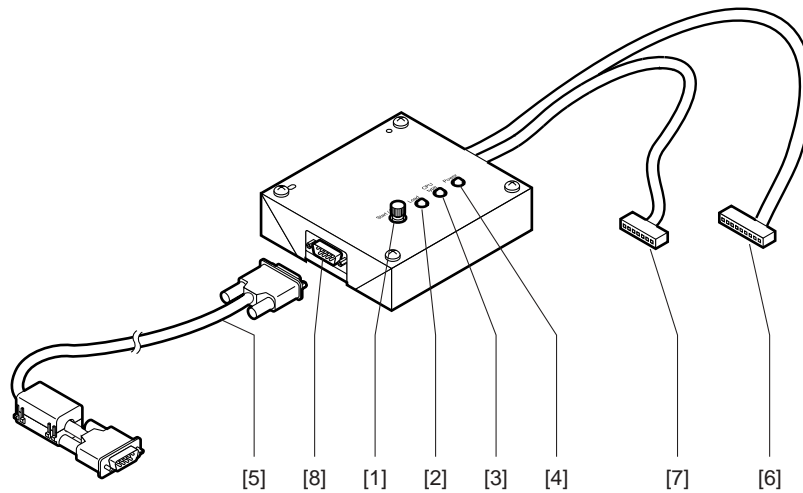

F-5-10

T-5-12

No.	Description	Function
[1]	START/STOP key	A key to be pressed when you start or stop download
[2]	LOAD LED	To be lit when download is available.
[3]	Model LED	To be lit when the Finisher is connected.
[4]	Power LED	To be lit when power is supplied from the Finisher to the downloader PCB
[5]	RS-232C cable (straight full wiring; 9 pins)	A cable to connect the downloader PCB and a PC. Be sure to connect the cable in a way that its ferrite core comes to the PC side.
[6]	Cable A (9 pins) Length: approx. 70cm	A cable to connect the downloader PCB and other products

No.	Description	Function
[7]	Cable B (9 pins)Length: approx. 50cm	A cable to connect the downloader PCB and the Finisher
[8]	RS-232C connector	A connector to connect an RS-232C cable to the downloader PCB

3. Necessary Tool

The following item needs to be prepared for download.

Computer (PC)

Prerequisite: The download tool (Ver. 1.73E or higher) must be downloaded to the PC.

4. Download Procedures

a. Addition of ROM data

1) Store ROM data to be downloaded in the 'C:\ServTool\NewROM' folder.

2) Start up the Service Support Tool.

C:\ProgramFiles\Service Support Tool\bpchost.exe

3) Select [Controlling Data].

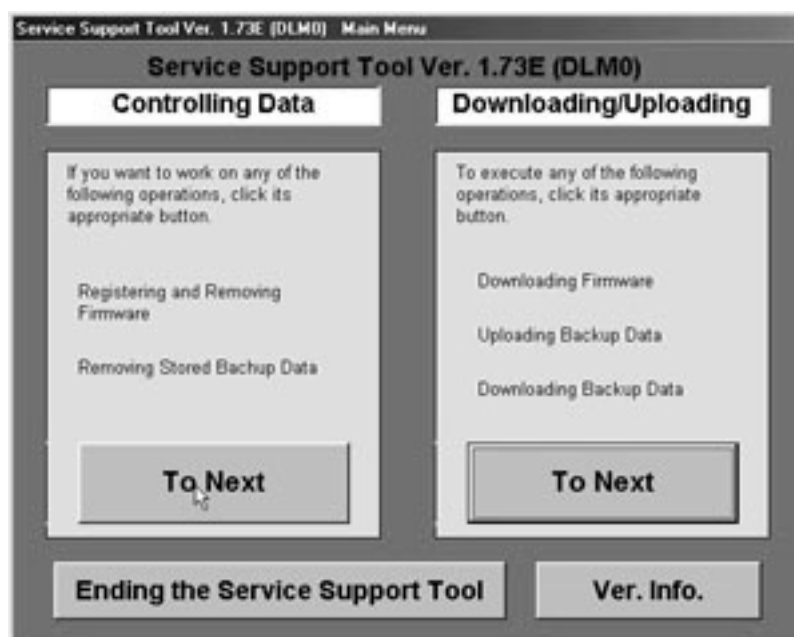

F-5-11

4) Select [Registering Firmware].

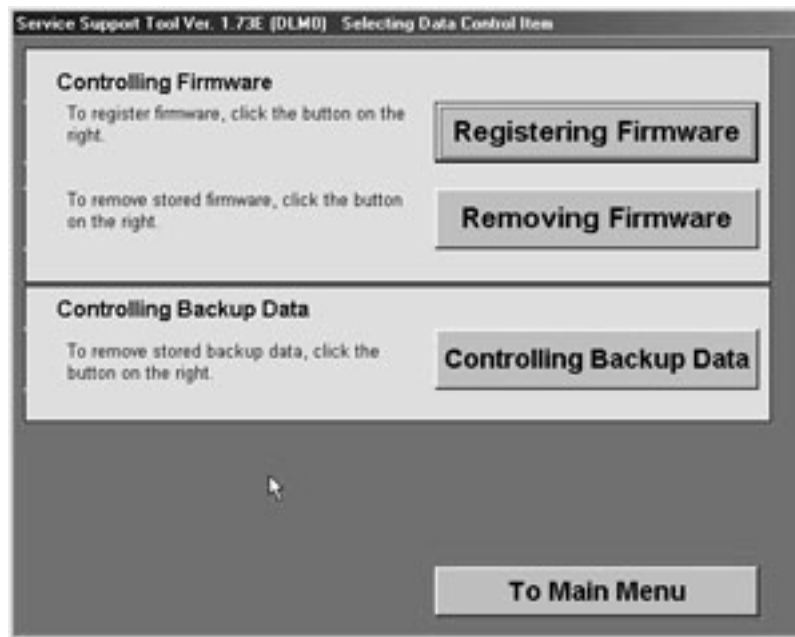

F-5-12

5) Select [Register from New ROM folder].

In response, the data will be registered, and the data inside the NewROM folder will be deleted.

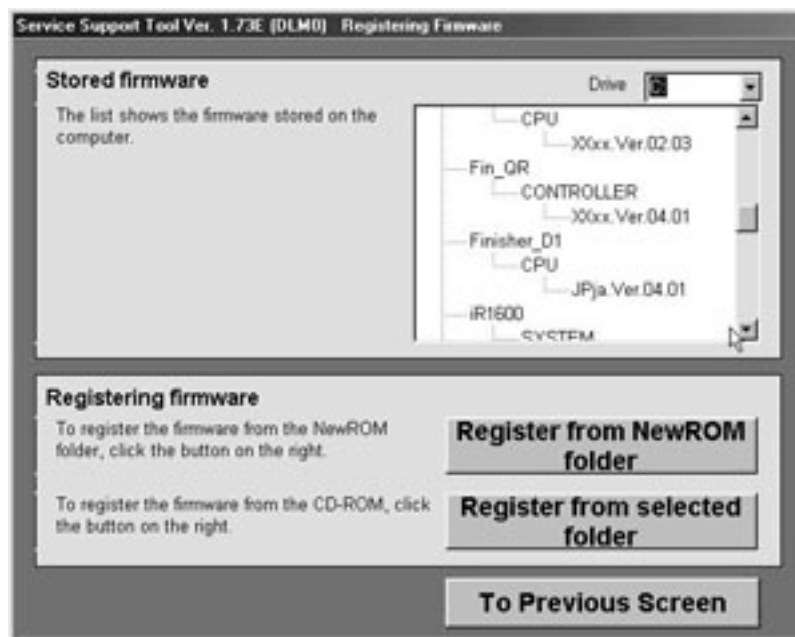

F-5-13

b. Connection to the Finisher

- 1) Turn off the power of the host machine.
- 2) Remove the rear cover of the Finisher.
- 3) Insert the cable B to J724 on the Finisher controller PCB.

- 4) Connect the RS-232C cable to the RS-232C connectors of the circuit board and the PC.
 - 5) Turn on the power of the host machine.
The power LED on the circuit board is lit.
- c. Download

 The error code E500 might occur during download. It does not affect the download operation and its results.

- 1) Start up the Service Support Tool.
C:\ProgramFiles\Service Support Tool\bpchost.exe
- 2) Select [Downloading/Uploading].

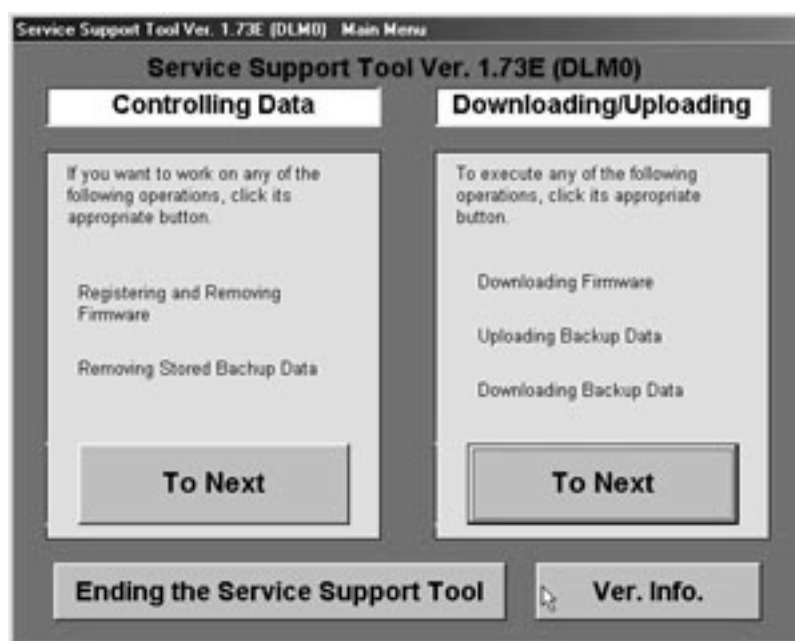

F-5-14

- 3) Press the START/STOP key.
LOAD LED is lit.
- 4) Select the Finisher.
When the model name you selected is highlighted, press the Connect key.

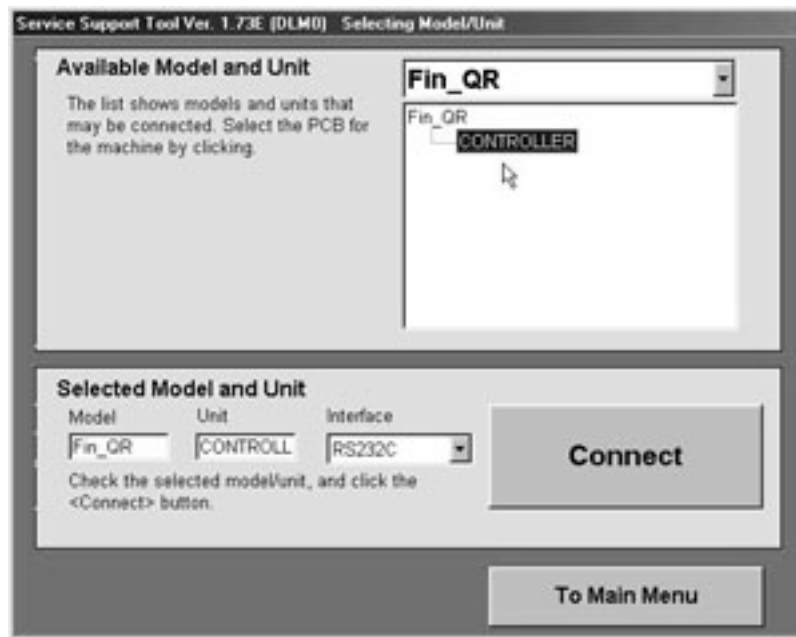

F-5-15

- 5) Follow the instructions on the screen to prepare for downloading.
 A press on [OK] will bring up the next screen.

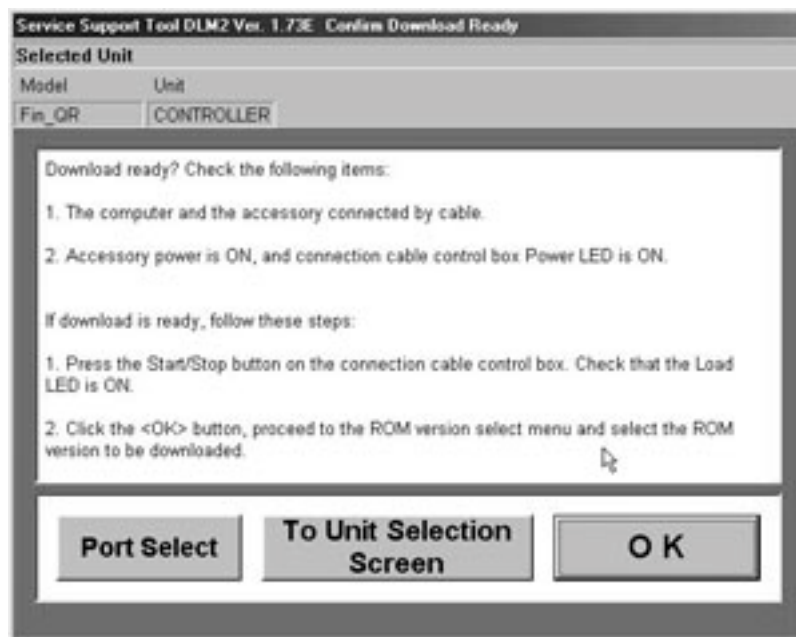

F-5-16

- 6) Select the version of the ROM to download.

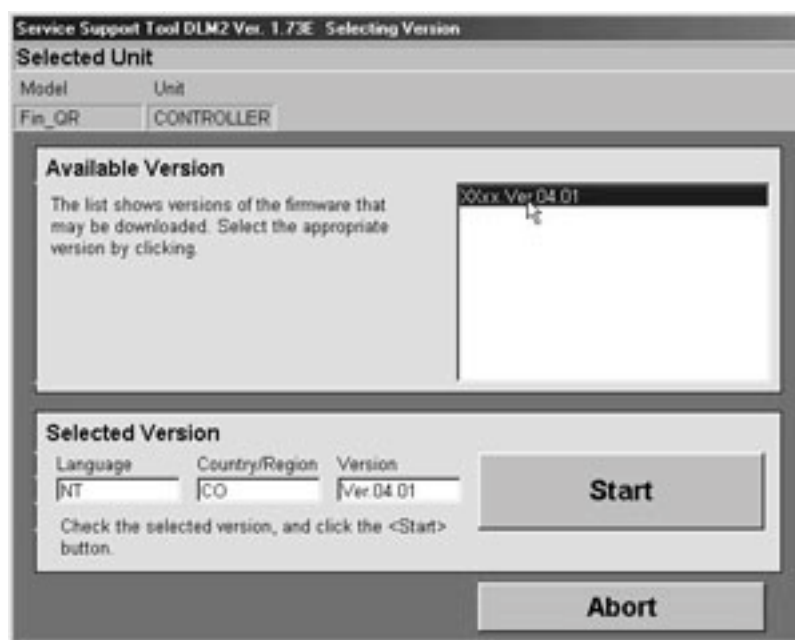

F-5-17

7) Press [Start] so that the computer and the downloaded PCB will start downloading the program.

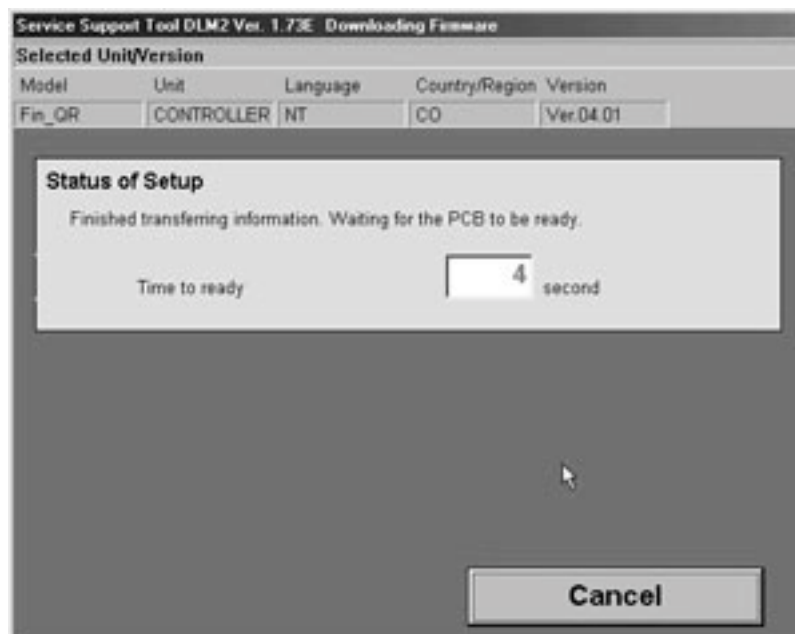

F-5-18

8) If downloading ended normally, press [OK].

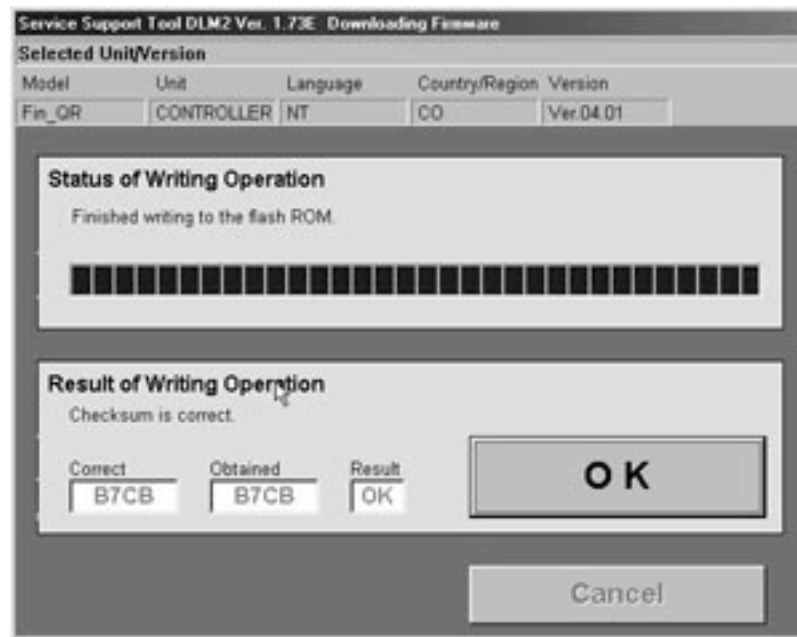

F-5-19

9) End the session as instructed on the screen.

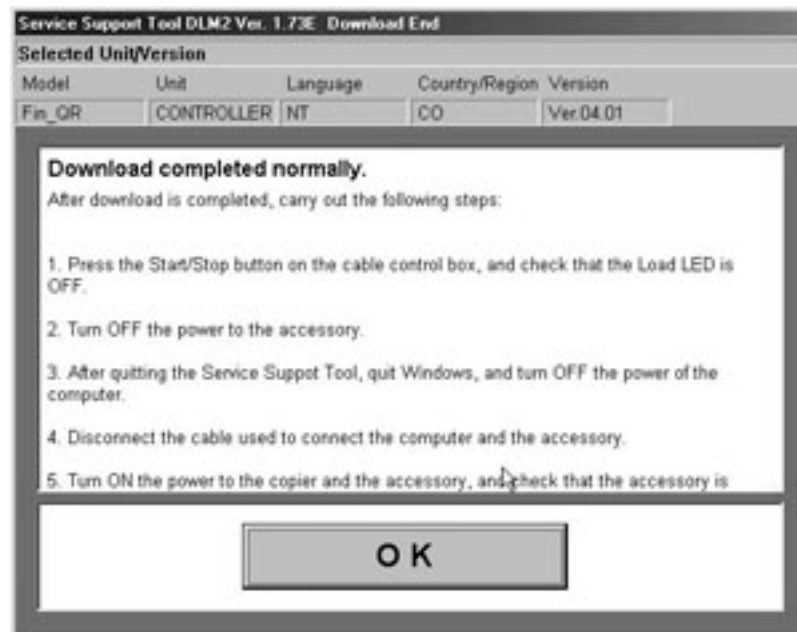

F-5-20

5. Release of Connection

1) Press the START/STOP key.

LOAD LED is turned off.

2) Turn off the power of the host machine.

3) Disconnect the cable B from the Finisher.

- 4) Mount the rear cover to the Finisher.
- 5) Turn on the power of the host machine.

5.8 Service Tools

5.8.1 Solvents and Oils

0003-4617

T-5-13

No.	Name	Description	Composition	Remarks
1	Vic Clean	Cleaning: e.g., glass, plastic, rubber parts, external covers	Hydrocarbon(fluori ne family) Alcohol Surface activating agent Water	Do not bring near fire. Procure locally. Isopropyl alcohol may be substituted.
2	Lubricant	Sliding units	Silicone oil	MOLYKOTE EM30-L

Chapter 6 Error Code

Contents

6.1 Overview	6-1
6.1.1 Overview	6-1
6.2 User Error Code.....	6-2
6.2.1 Staple is absent	6-2
6.2.2 Stapler safety protection function activated	6-2
6.2.3 Stack tray overstacking	6-3
6.2.4 Stapler staple jam	6-3
6.3 Service Error Code	6-4
6.3.1 E500.....	6-4
6.3.2 E505.....	6-4
6.3.3 E514.....	6-4
6.3.4 E519.....	6-5
6.3.5 E530.....	6-5
6.3.6 E531	6-6
6.3.7 E532.....	6-6
6.3.8 E535.....	6-6
6.3.9 E537.....	6-7
6.3.10 E540.....	6-7
6.3.11 E542.....	6-8
6.3.12 E584.....	6-8
6.3.13 Temporary Functional Limit	6-8

6.1 Overview

6.1.1 Overview

0003-4660

The CPU on the machine's finisher controller PCB is equipped with a mechanism to check the machine condition as needed; when it detects a fault, the machine communicates the fact to the host machine in the form of a code and a detail code.

The host machine indicates the code on its control panel. (The detail code may be checked in the host machine's service mode.)

6.2 User Error Code

6.2.1 Staple is absent

0003-4663

T-6-1

Error Description	Condition	Detection timing	Machine operation	Resetting
Staple is absent	The staple cartridge has run out of staples.	Always monitored	Normal operation can be continued. However, whether to operate or not depends on the instruction from the host machine.	Replace the staple cartridge; or, set it correctly.

6.2.2 Stapler safety protection function activated

0003-4664

T-6-2

Error Description	Condition	Detection timing	Machine operation	Resetting
Stapler safety protection function activated	Stapler safety protection function was activated.	When starting staple operation.	Stop staple motor (M41).	Stack ejection without stapling.

6.2.3 Stack tray overstacking

0003-4665

T-6-3

Error Description	Condition	Detection timing	Machine operation	Resetting
Stack tray overstacking	The number of sheets on the ejection tray has exceeded the stackable sheet or set count.	After ejecting the sheet/set exceeding the limit.	Normal operation will continue.	Remove paper from ejection tray.

6.2.4 Stapler staple jam

0003-4666

T-6-4

Error Description	Condition	Detection timing	Machine operation	Resetting
Stapler staple jam	Staple could not be positioned correctly.	When positioning staple.	Normal operation can be continued. However, whether to operate or not depends on the instruction from the host machine.	Check staple cartridge and repeat staple positioning.

6.3 Service Error Code

6.3.1 E500

0003-7593

T-6-5

Code	Detail	Error Description	Detection timing
E500	0001	Communication error	The communication with the host machine is interrupted.

6.3.2 E505

0003-4671

T-6-6

Code	Detail	Error Description	Detection timing
E505	0001	Backup RAM	The checksum for the finisher controller PCB has an error when the power is turned on.

6.3.3 E514

0003-4680

T-6-7

Code	Detail	Error Description	Detection timing
E514	8001	Rear end assist motor(M39)/	The stapler does not leave the rear end assist home position when the rear end assist motor has been driven for 3 seconds.
	8002	Rear end assist home position sensor (PI39)	

6.3.4 E519

0003-4681

T-6-8

Code	Detail	Error Description	Detection timing
E519	8001	Gear change motor(M40)/ Gear change homeposition sensor (PI49)	The stapler does not return to the gear change home position when the gear change motor has been drive for 387 pulses.
	0002		The stapler does not leave the gear changehome position when the gear change motorhas been drive for 387 pulses.

6.3.5 E530

0003-4672

T-6-9

Code	Detail	Error Description	Detection timing
E530	8001	Aligning plate frontmotor (M33)/ Aligning plate fronthome position sensor(PI36)	The aligning plate does not return to aligning plate front home position sensor when the alignment plate front motor has been driven for 4 seconds.
	8002		The aligning plate does not leave the aligningplate front home position sensor when thealignment plate front motor has been driven for 4 seconds.

6.3.6 E531

0003-4674

T-6-10

Code	Detail	Error Description	Detection timing
E531	8001	Staple motor(M41)/ Staple home positiondetect switch	The stapler does not return to the staple home position when the staple motor has been driven for 0.4 sec.
	8002		The stapler does not leave the staple home positionwhen the staple motor has been driven for 0.4 sec.

6.3.7 E532

0003-4675

T-6-11

Code	Detail	Error Description	Detection timing
E532	8001	Stapler shift motor(M35)/ Stapler shift homeposition sensor (P140)	The stapler does not return to the stapler shift home position when the stapler shift motor has been driven for 20 seconds.
	8002		The stapler does not leave the stapler shifhome position when the stapler shift motor hasbeen driven for 5 seconds.

6.3.8 E535

0003-4677

T-6-12

Code	Detail	Error Description	Detection timing
E535	8001	Swing motor (M36)/Swing home positionsensor (PI35)	The stapler does not return to the swing home position when the swing motor has bee driven for 3 seconds.
	8002		The stapler does not leave the swing home position when the swing motor has been driven for 3 seconds.

6.3.9 E537

0003-4673

T-6-13

Code	Detail	Error Description	Detection timing
E537	8001	Aligning plate rear motor (M34)/ Aligning plate rear home position sensor(PI37)	The aligning plate does not return to aligning plate rear home position sensor when the alignment plate rear motor has been driven for 4 seconds.
	8002		The aligning plate does not leave the aligning plate rear home position sensor when the alignment plate rear motor has been driven for 4 seconds.

6.3.10 E540

0003-4678

T-6-14

Code	Detail	Error Description	Detection timing
E540	8001	Tray 1 shift motor(M37)/ Tray 1 shift area sensor PCB	If the tray does not return to home position when the tray 1 shift motor is driven for 20 seconds.
	8002		If the tray does not move to other area when tray 1 shift motor is driven for 4 seconds.
	8003		When tray 1 switch is activated while tray 1 is operating.

6.3.11 E542

0003-6508

T-6-15

Code	Detail	Error Description	Detection timing
E542	8001	Tray 2 shift motor (M38)/ Tray 2 shift area sensor PCB	If the tray does not return to home position when the tray 2 shift motor is driven for 20 seconds. If the tray does not move to other area when tray 2 shift motor is driven for 4 seconds.
	8002		When reached to the upper limit area before the paper surface sensor detects paper surface during the paper surface detection operation.

6.3.12 E584

0003-4679

T-6-16

Code	Detail	Error Description	Detection timing
E584	8001	Stack ejection motor (M32)/ Shutter open/close clutch (CL31)/Shutter home position sensor (PI45)	The stapler does not return to the shutter home position when the stack ejection motor has been driven for 3 seconds.
	0002		The stapler does not leave the shutter home position when the stack ejection motor has been driven for 3 seconds.

6.3.13 Temporary Functional Limit

0003-6726

1. Overview

The machine has a feature to temporarily enter the limited operation mode to perform only paper delivery, when an error is encountered. The machine can continue to operate in this limited mode until the error is removed.

In the limited operation mode, stapling, alignment, and punching (only applicable when equipped with optional puncher unit) are not performed, while the inlet sensor (PI33) and feed path sensor (PI34) remain enabled to detect any jam.

2. Operation

1) When the host machine has started up, use service mode or user mode as follows:

1-a) Service Mode

Set '1' for the following: SORTER>OPTION>MD-SPRTN.

1-b) User Mode

Press [limit function mode]; when a Confirmation screen has appeared, press [yes].

3) Turn off and then on the main power switch of the host machine.

3. Communication with the Host Machine

1) When the main power switch is turned on, the DC controller PCB will communicate to the main controller PCB that a functional limit has been imposed. The control panel will indicate that a functional limit has been imposed on the finisher.

2) The DC controller PCB backs up information on the functional limit.

3) Each time pickup occurs, the main controller PCB communicates the presence of a functional limit to the DC controller PCB.

4) The DC controller PCB executes control only on delivery operation.

T-6-17

Functional Limit and Error Code

E514	Rear end assist motor error
E530	Front aligning plate motor error
E531	Staple motor error
E532	Stapler shift motor error
E535	Swing motor error
E537	Rear aligning plate motor error
E540	Tray 1 shift motor error
E542	Tray 2 shift motor error
E590	Punch motor error
E591	Scrap full detector sensor error
E592	Trailing edge/Horizontal registration sensor error
E593	Horizontal registration motor error

* E590 to E593 are when equipped puncher unit (option).

Mar 22 2004

Canon